

REV	DATE	DRAWN BY	DESCRIPTION	ADDITIONAL DIBS NOTE
1	12/22	JFK		

**PRELIMINARY**

CONCEPTUAL IMPROVEMENT PLAN  
 FOR UNDERHILL FARM  
 NYS ROUTE 118 & UNDERHILL AVENUE  
 TOWN OF YORKTOWN  
 WESTCHESTER COUNTY  
 NEW YORK

WESTCHESTER OFFICE  
 400 Columbus Avenue  
 Suite 180E  
 Valhalla, NY 10595  
 Phone: 914.347.7500  
 Fax: 914.347.7266

SCALE:	DATE:	DRAWN BY:	CHECKED BY:
AS SHOWN	1/5/21	P.W.G.	P.J.G.
PROJECT NUMBER:	DRAWING NAME:		
20006297A	R-CNPT-LAYT-ALT2		

PEDESTRIAN RRFB ACCOMMODATION PLAN

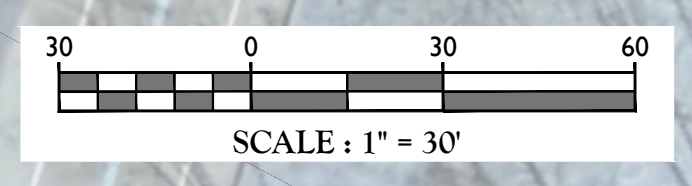
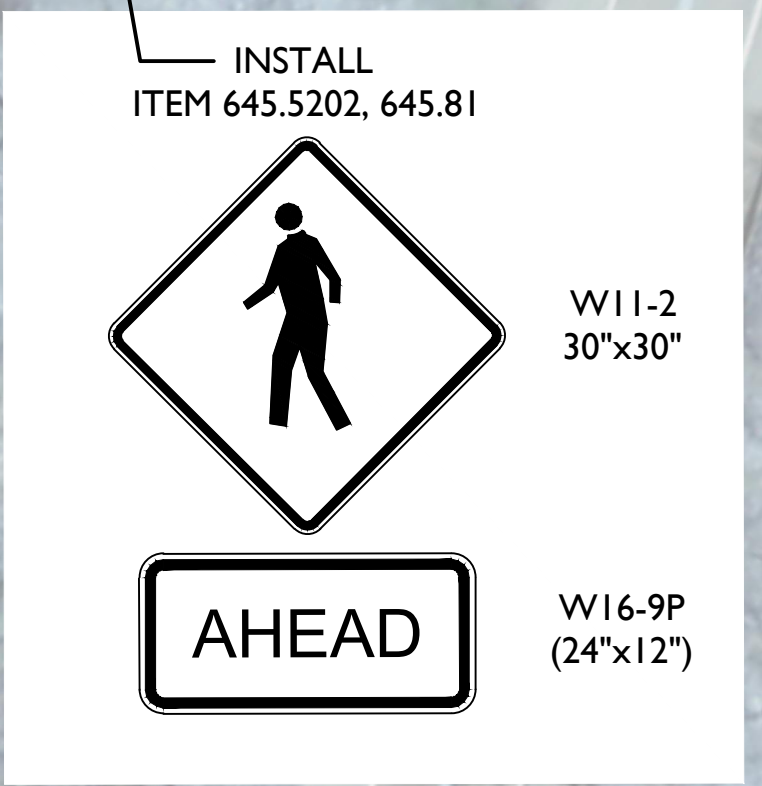
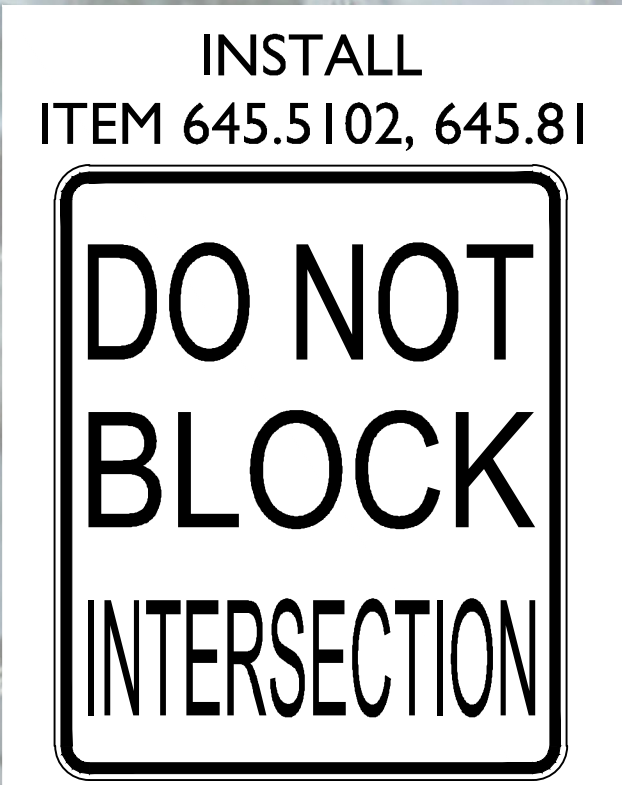
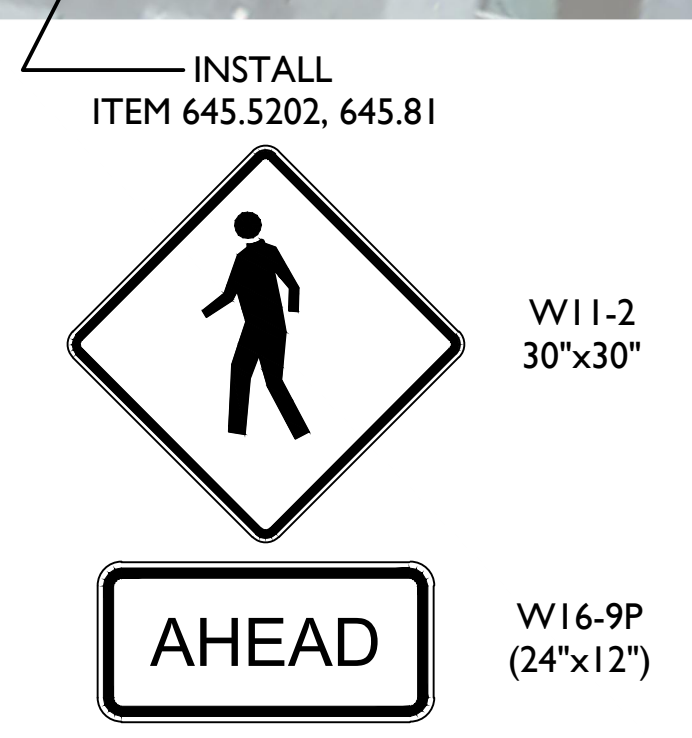
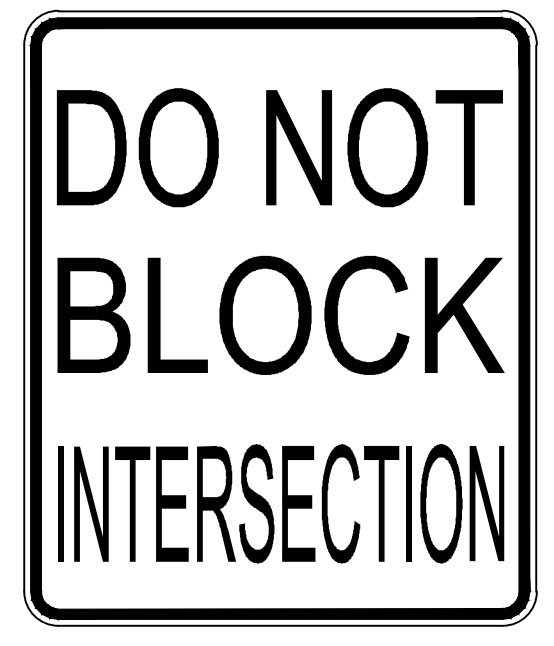
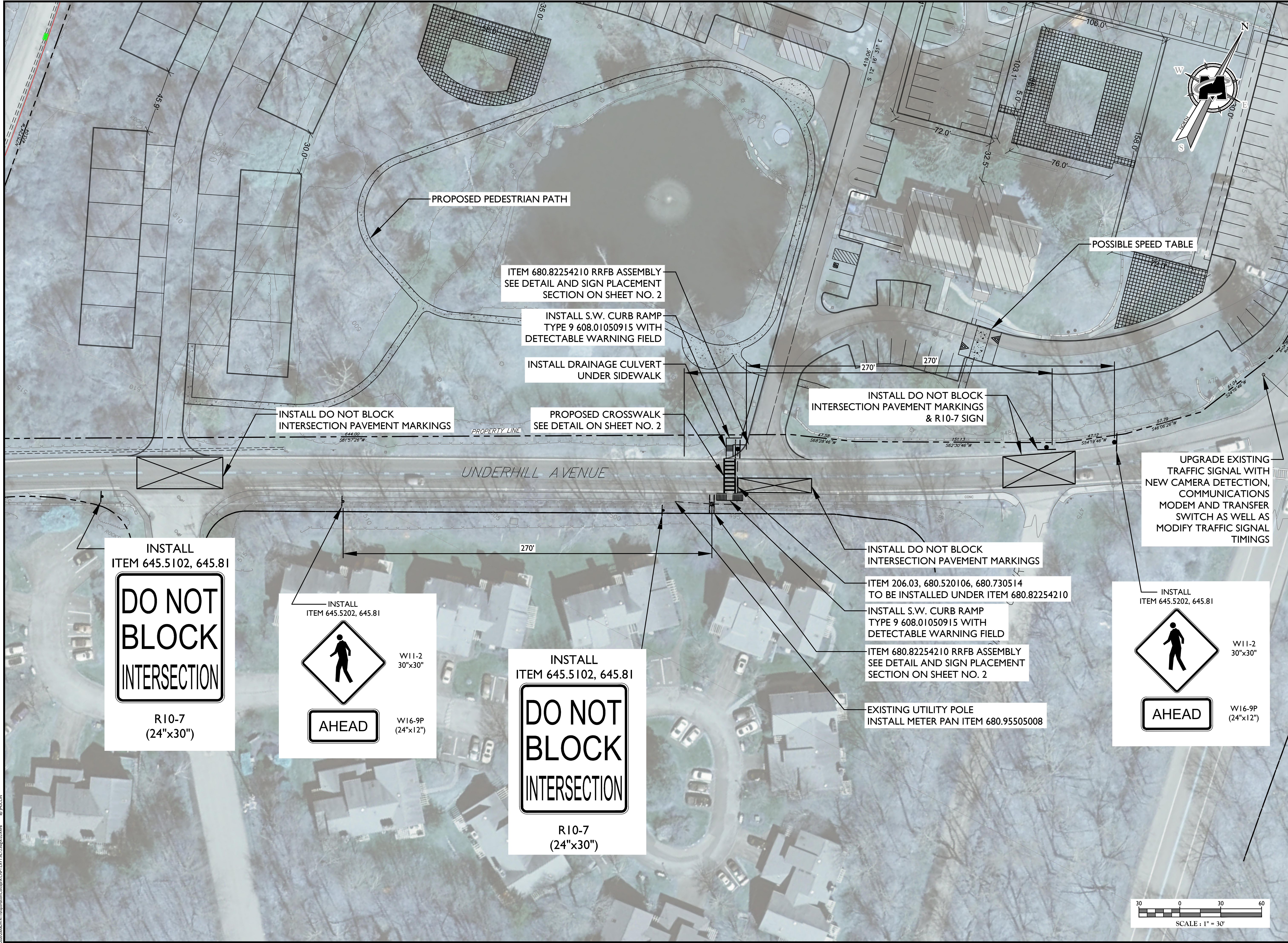

- NEW JERSEY
- NEW MEXICO
- NEW YORK
- MARYLAND
- PENNSYLVANIA
- GEORGIA
- VIRGINIA
- TEXAS
- FLORIDA
- TENNESSEE
- NORTH CAROLINA
- COLORADO
- SOUTH CAROLINA

Copyright © 2022, Maser Consulting. All Rights Reserved. This drawing and all the information contained herein is authorized for use only by the party for whom the services were contracted or to whom it is certified. This drawing may not be copied, reused, disclosed, distributed or relied upon for any other purpose without the express written consent of Maser Consulting.

**811** PROTECT YOURSELF  
 ALL STATES REQUIRE NOTIFICATION OF EXCAVATION. DESIGNERS OR ANY PERSON PREPARING TO DISTURB THE EARTH'S SURFACE ANYWHERE IN ANY STATE  
 Know what's below.  
 Call before you dig.  
 FOR STATE SPECIFIC DIRECT PHONE NUMBERS VISIT: WWW.CALL811.COM

REV	DATE	DRAWN BY	DESCRIPTION

PRELIMINARY

PRELIMINARY CONCEPT  
 PLAN  
 FOR  
 UNDERHILL FARM  
  
 NYS ROUTE 118 &  
 UNDERHILL AVENUE  
  
 TOWN OF YORKTOWN  
 WESTCHESTER COUNTY  
 NEW YORK

**WESTCHESTER OFFICE**  
 400 Columbus Avenue  
 Suite 180E  
 Valhalla, NY 10595  
 Phone: 914.347.7500  
 Fax: 914.347.7266

SCALE: AS SHOWN	DATE: 1/5/21	DRAWN BY: P.W.G.	CHECKED BY: P.J.G.
PROJECT NUMBER: 20006297A		DRAWING NAME: R-DTL5	

DETAILS

SHEET NUMBER:  
**2 of 3**

**SIDEWALK AND CURB RAMP DETAIL NOTES:**

- WHERE A CHANGE IN DIRECTION IS REQUIRED TO UTILIZE A CURB RAMP, A TURNING SPACE SHALL BE PROVIDED AT THE BASE OR THE TOP OF CURB RAMP AS APPLICABLE. TURNING SPACES SHALL BE PERMITTED TO OVERLAP CLEAR SPACES.
- TURNING SPACES SHALL NOT BE DESIGNED WITH CROSS SLOPE GREATER THAN 1.5% IN ANY DIRECTION, WHILE PROVIDING POSITIVE DRAINAGE. THE MAXIMUM CROSS SLOPE FOR WORK ACCEPTANCE IS 2.0%. A NONSTANDARD FEATURE JUSTIFICATION IS REQUIRED WHERE TURNING SPACES EXCEED 2.0% IN ANY DIRECTION.
- BEYOND THE BOTTOM GRADE BREAK, A CLEAR SPACE OF 4'-0" X 4'-0" MINIMUM SHALL BE PROVIDED WITHIN THE WIDTH OF THE PEDESTRIAN CROSSWALK, AND OUTSIDE THE PARALLEL VEHICLE TRAVEL LANE. THE CLEAR SPACE MAY OVERLAP TURNING SPACES, DETECTABLE WARNING SURFACES, AND DROP CURBS.

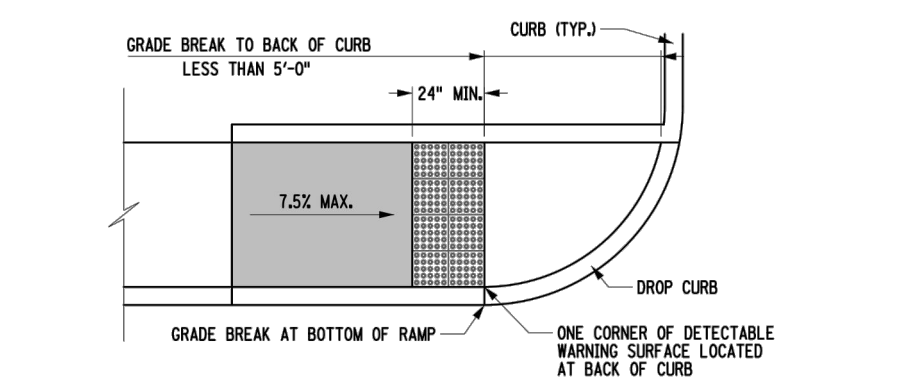

DETECTABLE WARNING FIELD PLACEMENT  
 OPTION 2  
 NOT TO SCALE

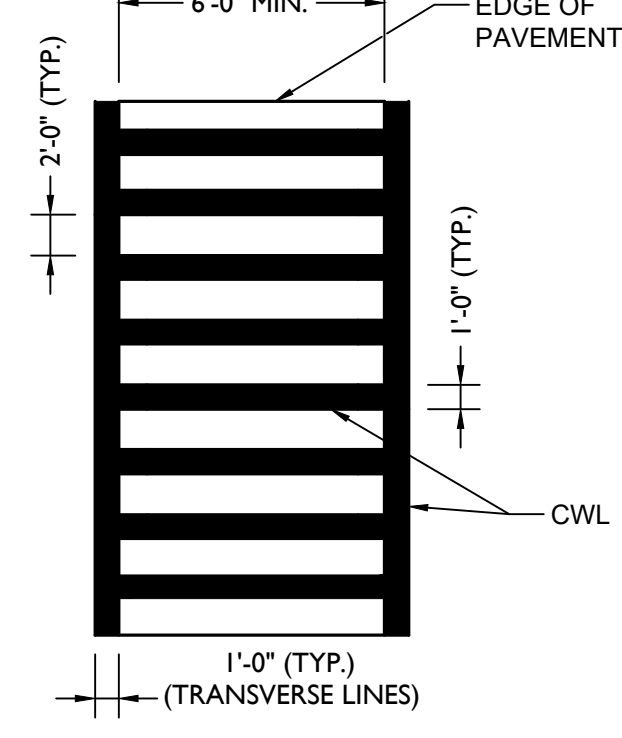

STRIPING LEGEND  
 CWL - SOLID WHITE CROSSWALK LINE 12" (ITEM 685.11)

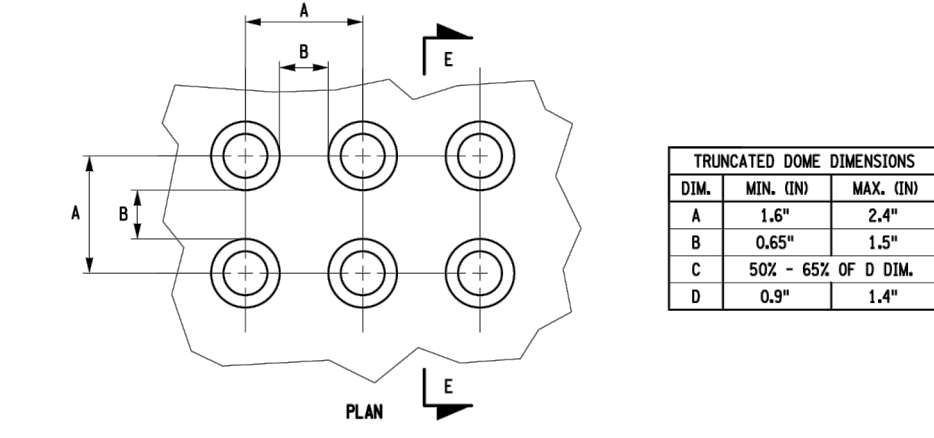

DETECTABLE WARNING DOME DETAIL  
 NOT TO SCALE

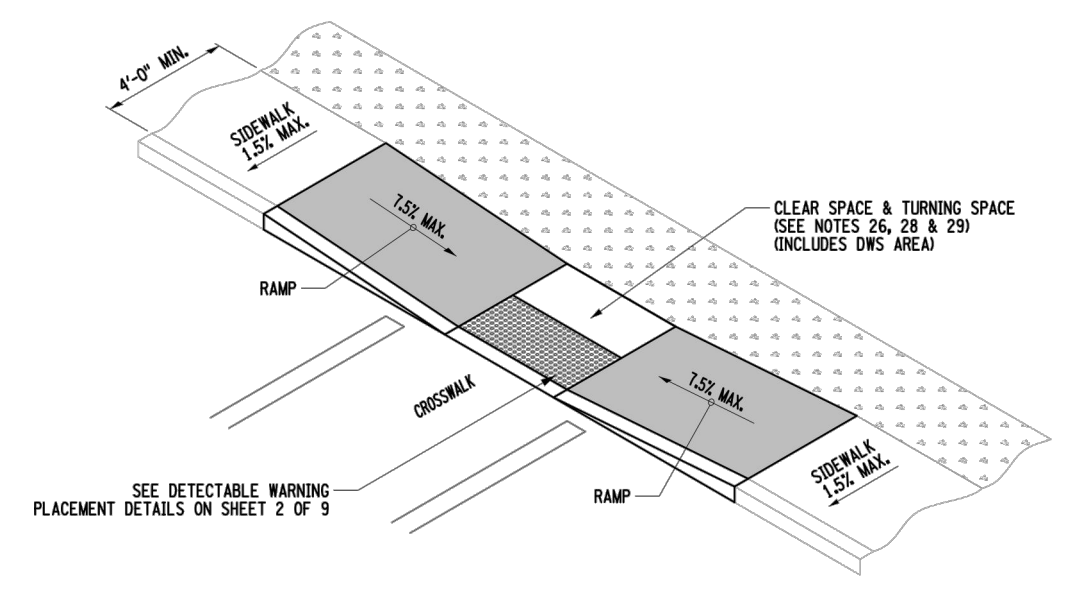

CURB RAMP CONFIGURATION: TYPE 9  
 MID BLOCK CROSSING OR T-INTERSECTION  
 NOT TO SCALE

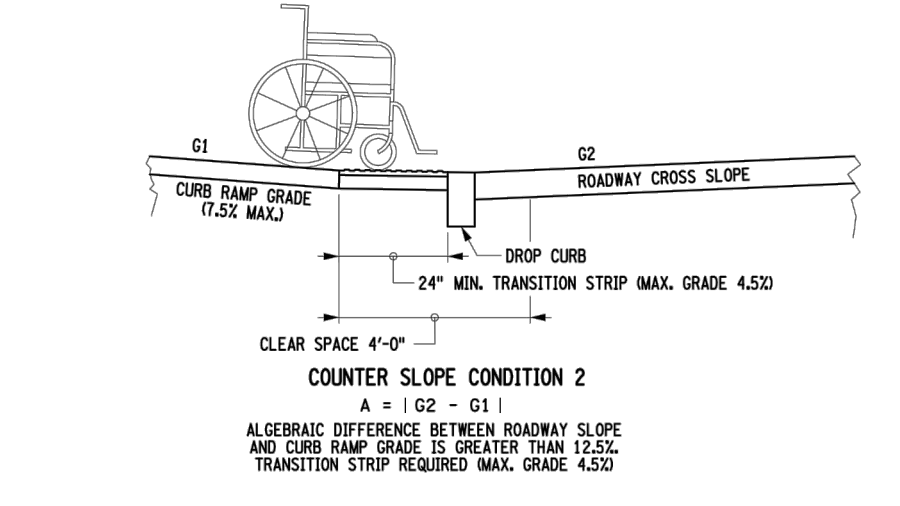
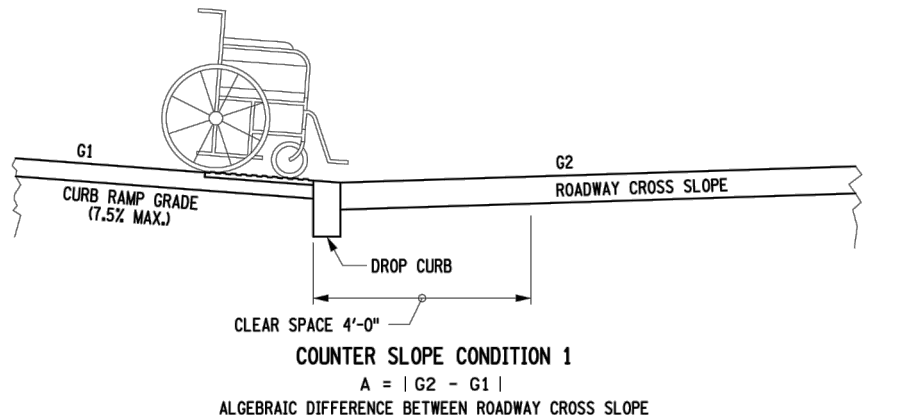

COUNTER SLOPE CONDITIONS  
 NOT TO SCALE

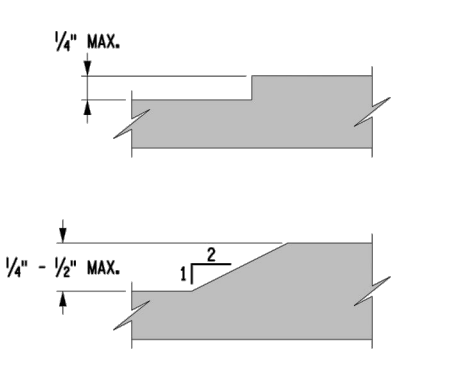

VERTICAL SURFACE DISCONTINUITIES  
 NOT TO SCALE

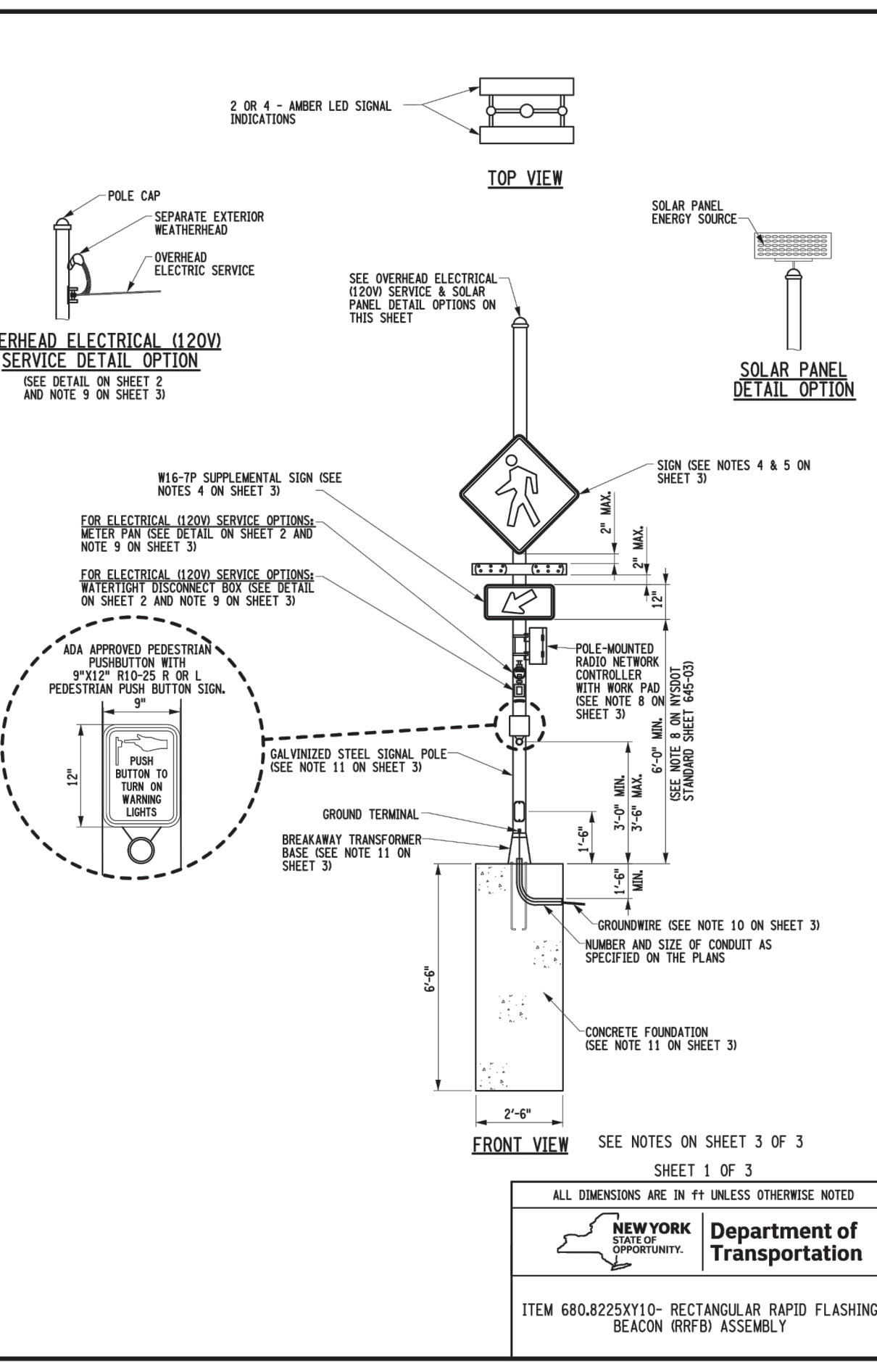

SHEET 1 OF 3  
 ALL DIMENSIONS ARE IN # UNLESS OTHERWISE NOTED  
 NEW YORK STATE DEPARTMENT OF TRANSPORTATION  
 ITEM 680.8225XY10- RECTANGULAR RAPID FLASHING BEACON (RRFB) ASSEMBLY

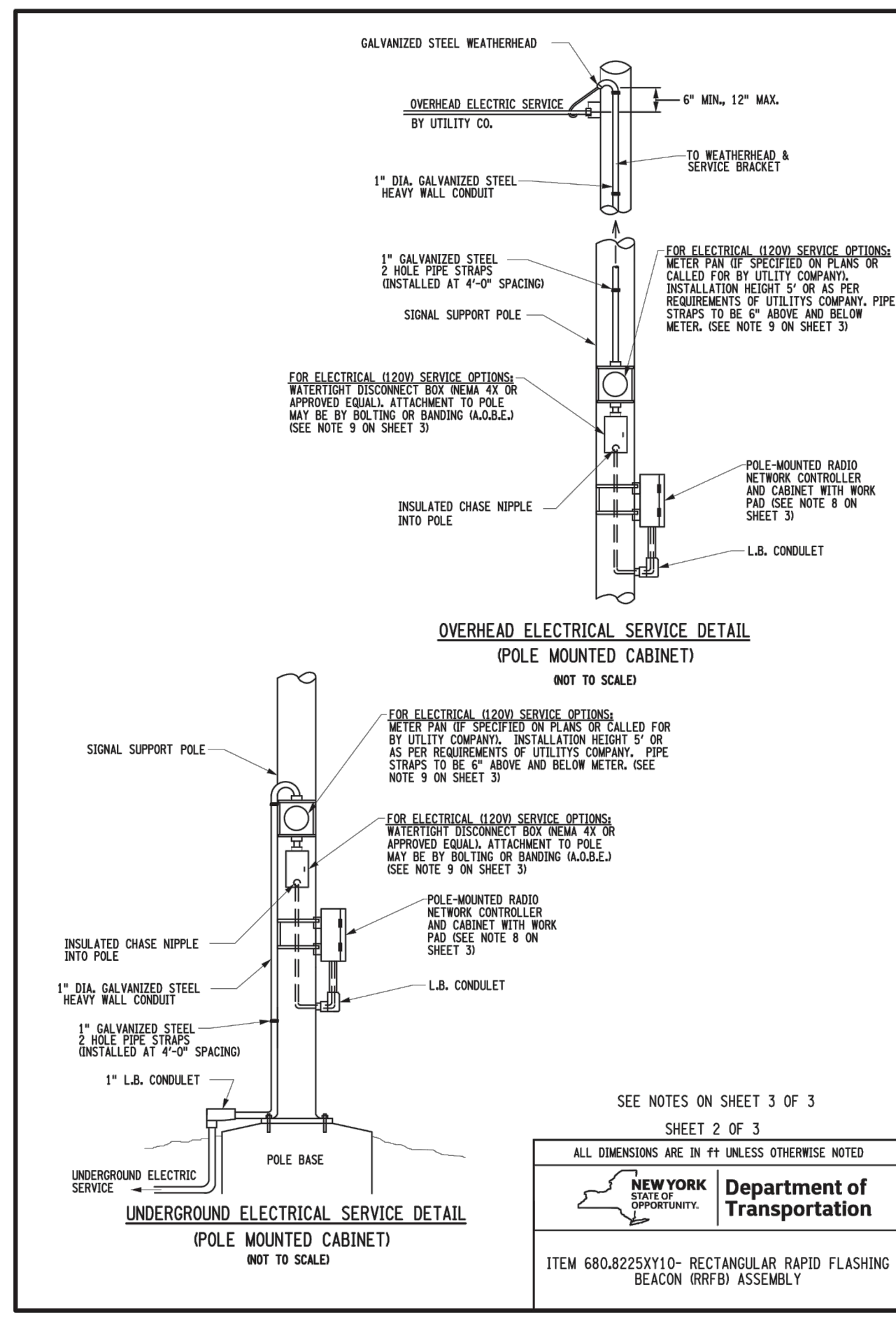

SHEET 2 OF 3  
 ALL DIMENSIONS ARE IN # UNLESS OTHERWISE NOTED  
 NEW YORK STATE DEPARTMENT OF TRANSPORTATION  
 ITEM 680.8225XY10- RECTANGULAR RAPID FLASHING BEACON (RRFB) ASSEMBLY

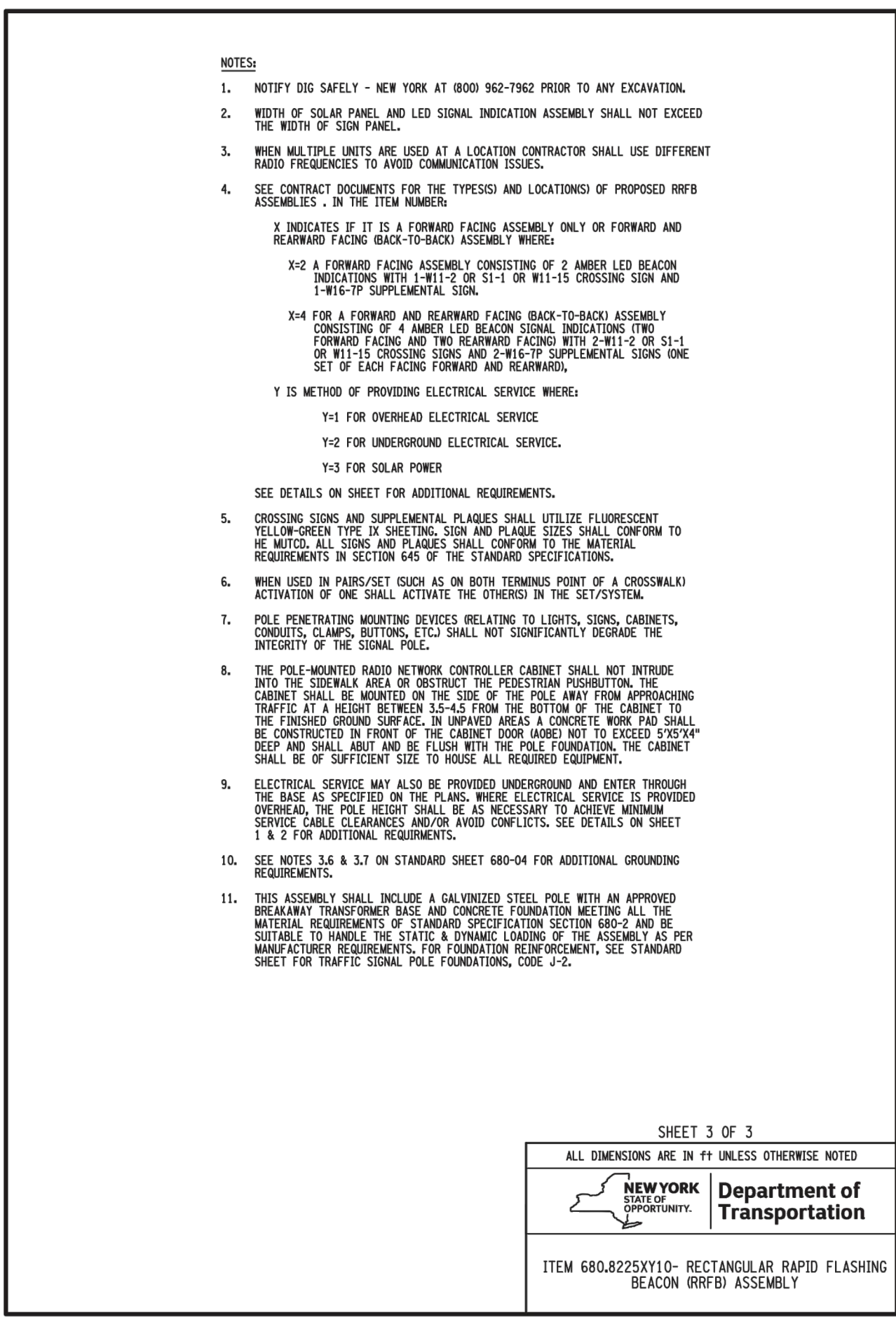

SHEET 3 OF 3  
 ALL DIMENSIONS ARE IN # UNLESS OTHERWISE NOTED  
 NEW YORK STATE DEPARTMENT OF TRANSPORTATION  
 ITEM 680.8225XY10- RECTANGULAR RAPID FLASHING BEACON (RRFB) ASSEMBLY

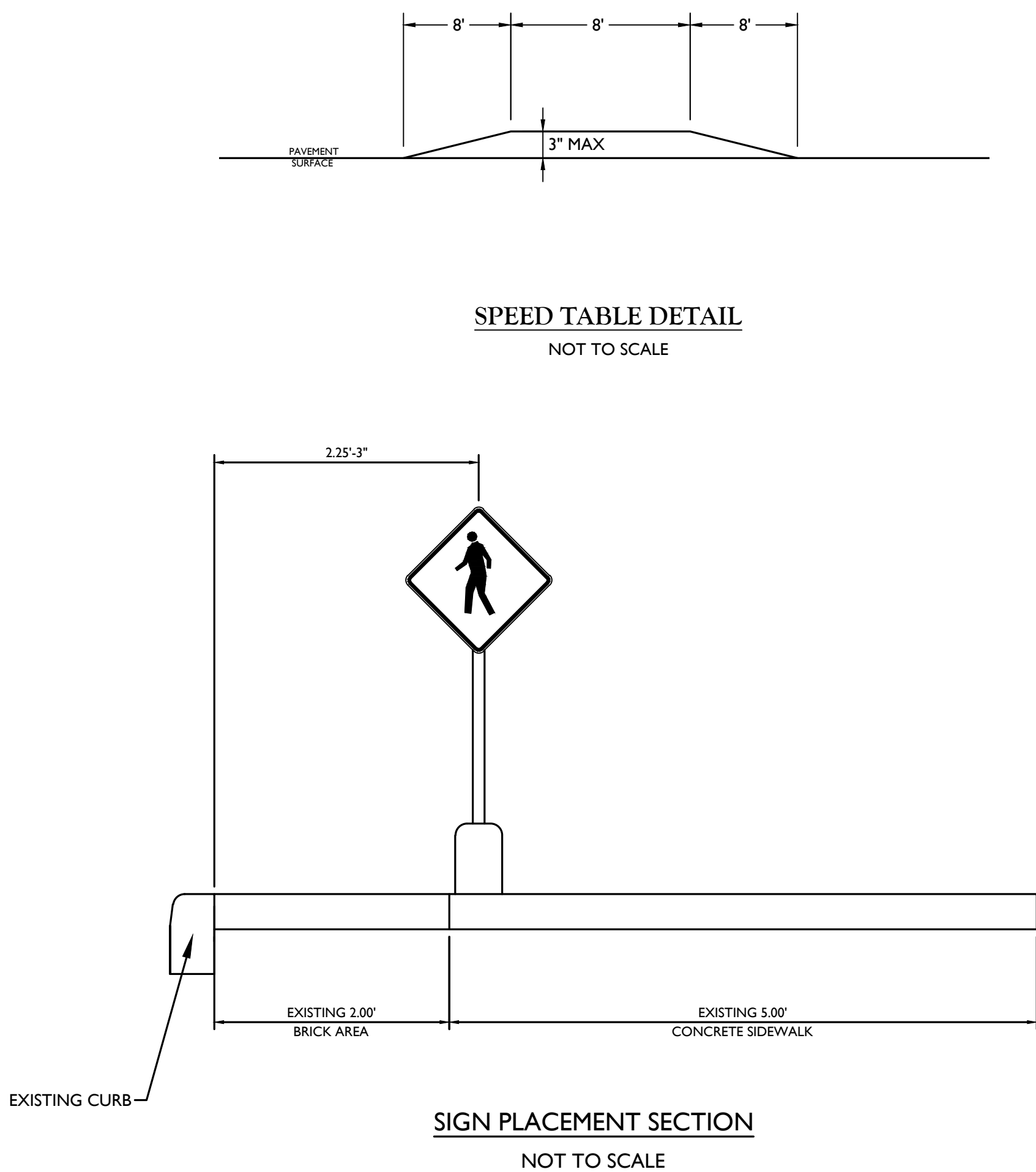

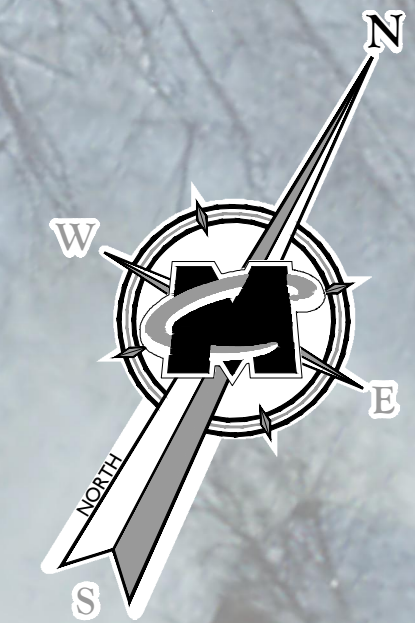

**MASER**  
 CONSULTING  
 WILL BE KNOWN AS COLLIER ENGINEERING & DESIGN IN 2021  
 Customer Loyalty through Client Satisfaction  
 www.maserconsulting.com

Office Locations:

NEW JERSEY	NEW MEXICO
NEW YORK	MARYLAND
PENNSYLVANIA	GEORGIA
VIRGINIA	TEXAS
FLORIDA	TENNESSEE
NORTH CAROLINA	COLORADO
SOUTH CAROLINA	

Copyright © 2022, Maser Consulting. All Rights Reserved. This drawing and all the information contained herein is authorized for use only by the party for whom the services were constructed or to whom it is certified. This drawing may not be copied, reused, disclosed, distributed or relied upon for any other purpose without the express written consent of Maser Consulting.

**811** PROTECT YOURSELF

ALL STATES REQUIRE NOTIFICATION OF EXCAVATORS, DESIGNERS, OR ANY PERSON PREPARING TO DISTURB THE EARTH'S SURFACE ANYWHERE IN ANY STATE.

Know what's below.  
Call before you dig.  
FOR STATE SPECIFIC DIRECT PHONE NUMBERS VISIT: WWW.CALL811.COM

REV	DATE	DRAWN BY	DESCRIPTION

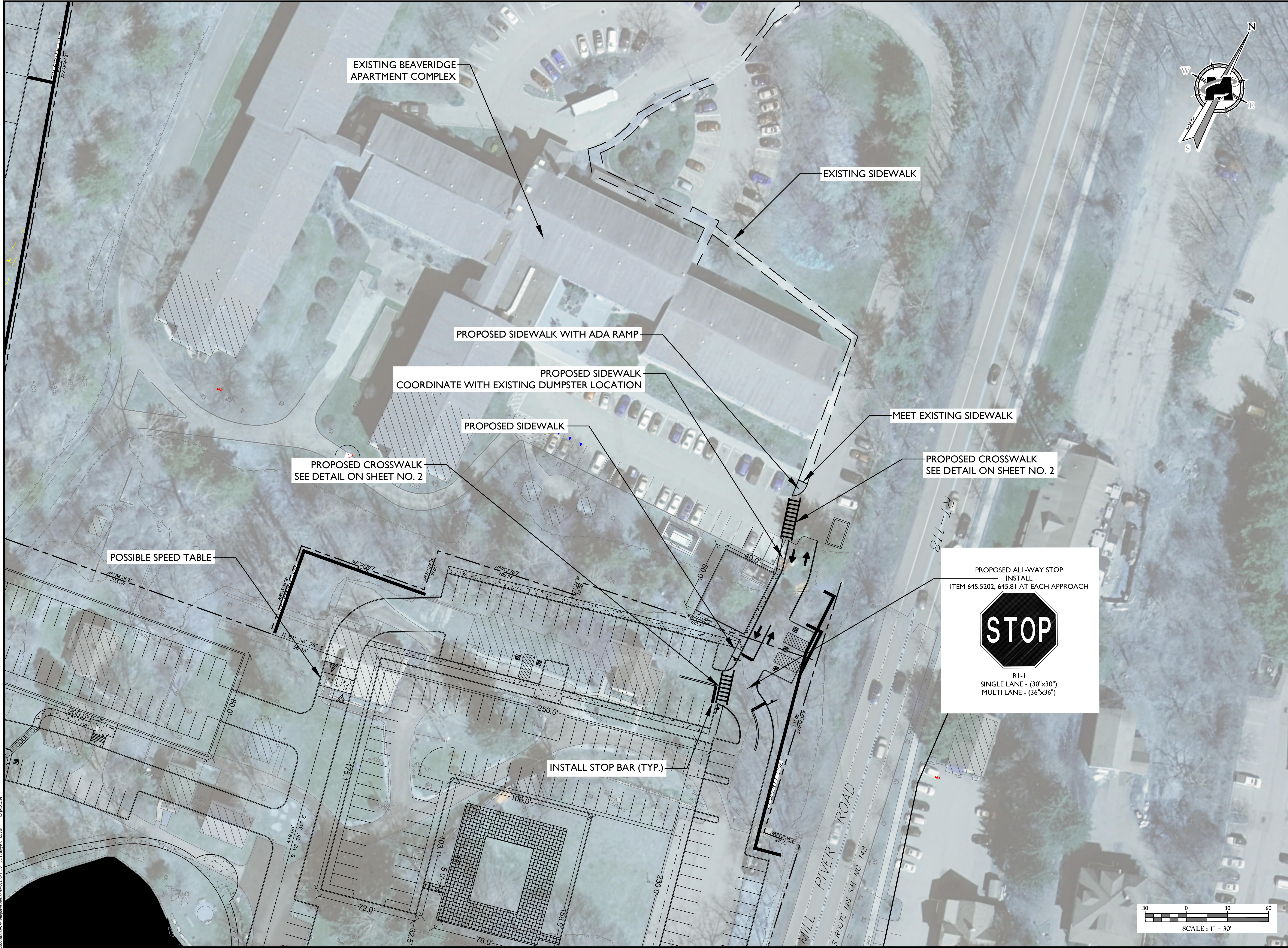

**PRELIMINARY**

CONCEPTUAL  
 IMPROVEMENT PLANS  
 FOR  
 UNDERHILL FARM  
  
 NYS ROUTE 118 &  
 UNDERHILL AVENUE  
 TOWN OF YORKTOWN  
 WESTCHESTER COUNTY  
 NEW YORK



WESTCHESTER OFFICE  
 400 Columbus Avenue  
 Suite 180E  
 Valhalla, NY 10595  
 Phone: 914.347.7500  
 Fax: 914.347.7266

SCALE: AS SHOWN	DATE: 1/5/21	DRAWN BY: P.W.G.	CHECKED BY: P.J.G.
PROJECT NUMBER: 20006297A	DRAWING NAME: R-CNPT-LAYT-ALT2		

PEDESTRIAN  
 ACCOMMODATION PLAN  
 SHEET NUMBER:  
 3 of 3



2020/09/09/04/01/Transmittal/Concept/CNPT-LAYT-ALT2.dwg R: BMCCON

NOTE: DO NOT SCALE DRAWINGS FOR CONSTRUCTION.



REV	DATE	DRAWN BY	DESCRIPTION

PRELIMINARY

FUTURE INTERSECTION  
 IMPROVEMENT PLAN  
 ALTERNATE 1  
 NYS ROUTE 118 &  
 UNDERHILL AVENUE  
 TOWN OF YORKTOWN  
 WESTCHESTER COUNTY  
 NEW YORK

**WESTCHESTER OFFICE**  
 400 Columbus Avenue  
 Suite 180E  
 Valhalla, NY 10595  
 Phone: 914.347.7500  
 Fax: 914.347.7266

SCALE AS SHOWN:	DATE: 1/5/21	DRAWN BY: P.W.G.	CHECKED BY: P.J.G.
PROJECT NUMBER: 20006297A		DRAWING NAME: R-CNPT-LAY1	

ALTERNATE INTERSECTION  
 IMPROVEMENT PLAN

NOTE: DO NOT SCALE DRAWINGS FOR CONSTRUCTION.

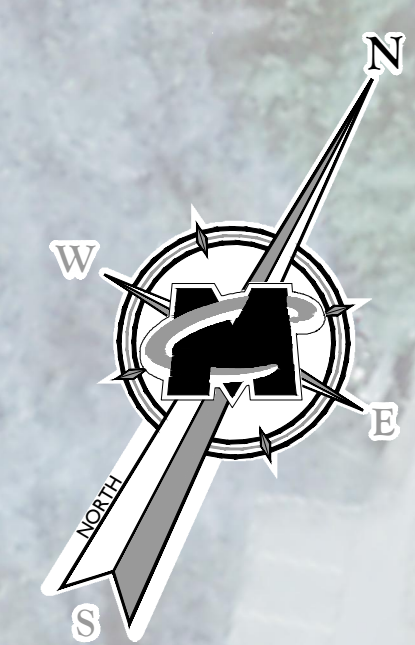
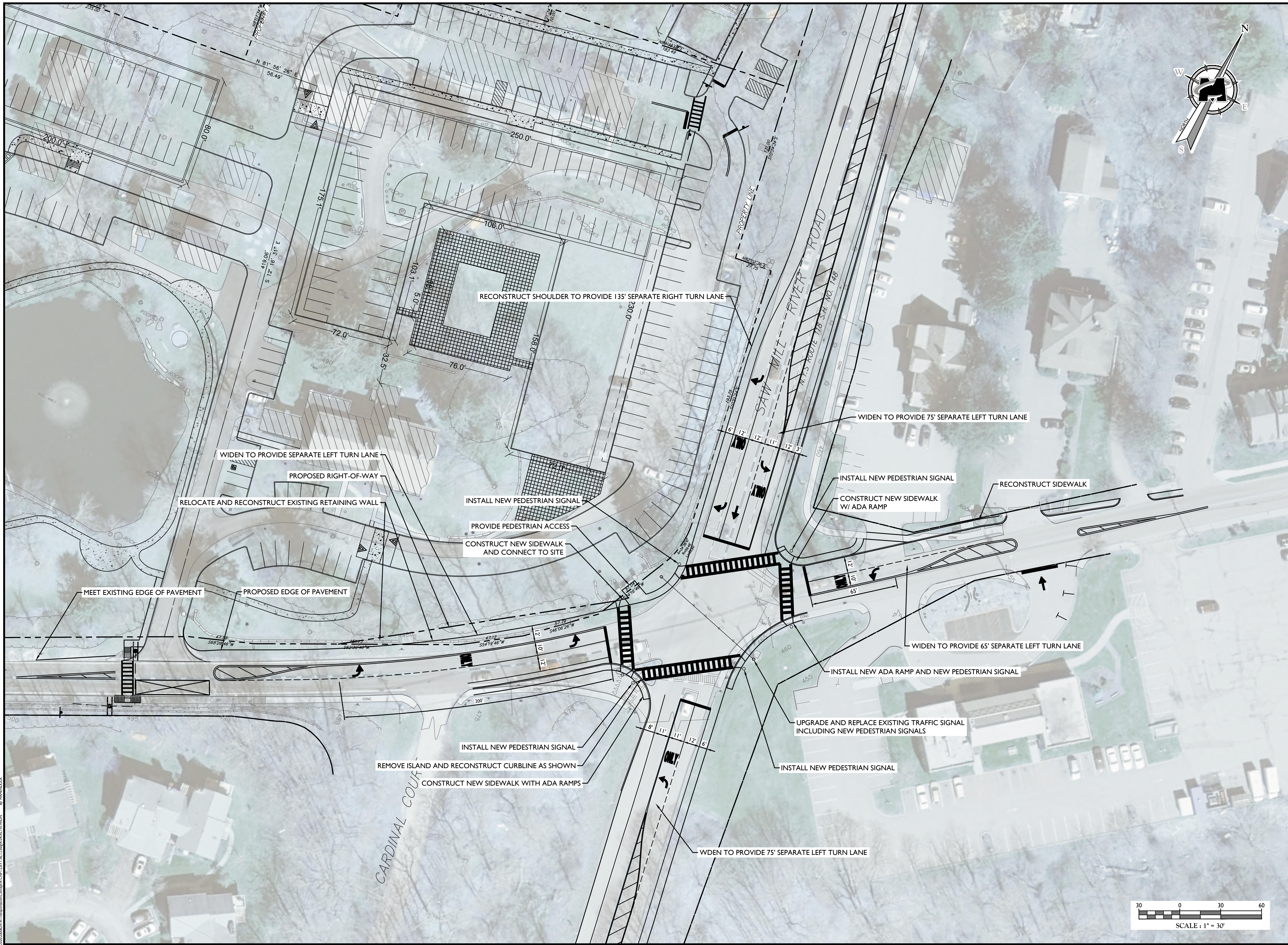

**MASER CONSULTING**  
 WILL BE KNOWN AS COLLIERS ENGINEERING & DESIGN IN 2021  
 Customer Loyalty through Client Satisfaction  
 www.maserconsulting.com  
 Office Locations:

- NEW JERSEY
- NEW YORK
- VIRGINIA
- FLORIDA
- NORTH CAROLINA
- SOUTH CAROLINA
- NEW MEXICO
- MARYLAND
- GEORGIA
- TEXAS
- TENNESSEE
- COLORADO

Copyright © 2022, Maser Consulting. All Rights Reserved. This drawing and all the information contained herein is authorized for use only by the party for whom the services were contracted or to whom it is certified. This drawing may not be copied, reused, disclosed, distributed or relied upon for any other purpose without the express written consent of Maser Consulting.

**811** PROTECT YOURSELF  
 ALL STATES REQUIRE NOTIFICATION OF EXCAVATORS, DESIGNERS, OR ANY PERSON PREPARING TO DISTURB THE EARTH'S SURFACE ANYWHERE IN ANY STATE  
 Know what's below.  
 Call before you dig.  
 FOR STATE SPECIFIC DIRECT PHONE NUMBERS VISIT: WWW.CALL811.COM

REV	DATE	DRAWN BY	DESCRIPTION

**PRELIMINARY**

**FUTURE INTERSECTION IMPROVEMENT PLAN**

**ALTERNATE 2**

**NYS ROUTE 118 & UNDERHILL AVENUE**

**TOWN OF YORKTOWN  
WESTCHESTER COUNTY  
NEW YORK**

**WESTCHESTER OFFICE**  
 400 Columbus Avenue  
 Suite 180E  
 Valhalla, NY 10595  
 Phone: 914.347.7500  
 Fax: 914.347.7266

SCALE:	DATE:	DRAWN BY:	CHECKED BY:
AS SHOWN	1/5/21	P.W.G.	P.J.G.
PROJECT NUMBER:	DRAWING NAME:		
20006297A	R-CNPT-LAY1-ALT2		

**PHASE 2 INTERSECTION IMPROVEMENT PLAN (ALTERNATE 2)**

SHEET NUMBER:  
 2 of 2



NOTE: DO NOT SCALE DRAWINGS FOR CONSTRUCTION.