

Revisions:

No.	Date
1	SEPTEMBER 21, 2022
2	MAY 10, 2023

Drawn by:
A. REXROAT

Checked by:
S. MEERSMA

Approved by:
C. DUNCAN

**SCS DELL 014136 YORKTOWN, LLC
 DELL AVENUE SOLAR FARM
 FIXED-TILT GROUND MOUNT SOLAR ENERGY SYSTEM
 DELL AVENUE, YORKTOWN, NEW YORK 10514**

Contract No:
431302

Scale:
AS SHOWN

Date:
AUGUST 30, 2022

Sheet:
LANDSCAPE PLANTING TEMPLATE,
SCHEDULES, & COORDINATE POINTS

Drawing No:
L-104

VISUAL MITIGATION PLANTING TEMPLATE - TYPE A

N.T.S.

LEGEND VISUAL MITIGATION PLANTING TYPE "A":

BUFFER TYPE "A" NOTE:

- SEE GENERAL SEEDING AND LANDSCAPE NOTES FOR ADDITIONAL PLANTING REQUIREMENTS AND SEED MIXTURES.
- THE 15-FOOT-WIDE PROPOSED BUFFER TYPE "A" WILL BE A MIX OF EVERGREEN TREES ARRANGED TO FORM A NATURAL APPEARANCE AND CONTINUOUS SOLID SCREEN. SEE THE PLANTING TEMPLATE FOR ARRANGE OF PLANTS AND THE PLANT SCHEDULES FOR TYPE AND SIZE.
- THE PROPOSED BUFFER TREATMENT MEETS THE GENERAL LANDSCAPING REQUIREMENTS PER THE TOWN OF YORKTOWN CODE FOR SOLAR POWER GENERATION SYSTEM AND FACILITIES SECTION 300-81.4 - E. (3) (E).
 - A GROUND MOUNTED SOLAR ENERGY SYSTEM SHALL BE FULLY SCREENED FROM ADJACENT RESIDENTIAL PROPERTIES, STREETS OR ROADS ON WHICH IT FRONT OR IS VISIBLE FROM, AND ANY OTHER VIEWS WHICH THE PLANNING BOARD DETERMINES IS NECESSARY.
- THIS BUFFER IS LOCATED ALONG THE FOLLOWING:
 - ALONG PUBLIC ROAD FRONTAGE/STREET RIGHT-OF-WAY
 - FACING A RESIDENTIAL PROPERTY
- SEE SHEET L103 FOR PLANT MATERIAL TOTALS

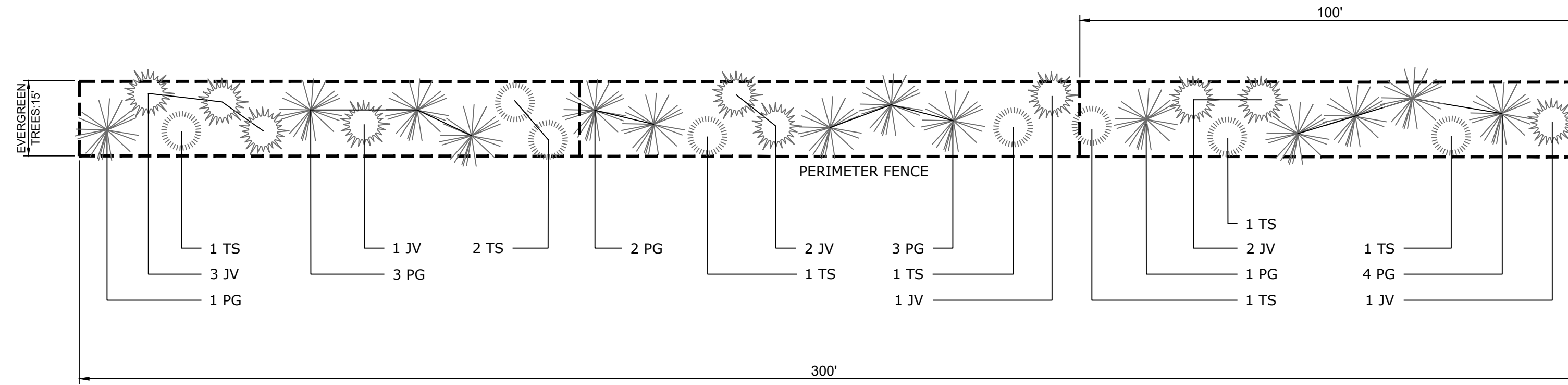

LEGEND VISUAL MITIGATION PLANTING TEMPLATE - TYPE A

LANDSCAPE PLANTING SCHEDULE (15' EVERGREEN VISUAL BUFFER/SCREENING EFFORT)

DECIDUOUS AND EVERGREEN TREES					
JV	JUNIPERUS VIRGINIANA EASTERN RED CEDAR	10	5'-6' HT.	B&B	40'-50' HT.
PG	PICEA GLAUCA WHITE SPRUCE	14	5'-6' HT.	B&B	40'-60' HT.
TS	THUJA STANDISHII X PLICATA 'GREEN GIANT' GREEN GIANT ARBORVITAE	8	5'-6' HT.	B&B	40'-50' HT.

VISUAL MITIGATION PLANTING SCHEDULE & COORDINATE TABLES - TYPE A

LEGEND - VM1 PLANTING TEMPLATE TYPE A
LANDSCAPE PLANTING SCHEDULE TOTAL MITIGATION LENGTH = 185 LF

EVERGREEN TREES					
SYMBOL	BOTANICAL NAME/ COMMON PLANT NAME	QUANTITY	SIZE	ROOT	MATURE HEIGHT
JV	JUNIPERUS VIRGINIANA EASTERN RED CEDAR	6	5'-6' HT.	B&B	40'-50' HT.
PG	PICEA GLAUCA WHITE SPRUCE	9	5'-6' HT.	B&B	40'-60' HT.
TS	THUJA STANDISHII X PLICATA 'GREEN GIANT' GREEN GIANT ARBORVITAE	5	5'-6' HT.	B&B	40'-50' HT.

VM1 - COORDINATES

VM1 - VEGETATIVE BUFFER / SCREEN MITIGATION TABLE					
NUMBER	MITIGATION TYPE	LENGTH	LINE/CHORD DIRECTION	START EASTING, NORTHING	END EASTING, NORTHING
L1	TYPE A	87	N32° 47' 12.82"W	E:689489.5216, N:866952.6692	E:689442.5172, N:867025.6424
L2	TYPE A	98	N33° 16' 12.18"E	E:689442.5172, N:867025.6424	E:689496.3927, N:867107.7535

LEGEND - VM2 PLANTING TEMPLATE TYPE A
LANDSCAPE PLANTING SCHEDULE TOTAL MITIGATION LENGTH = 60 LF

EVERGREEN TREES					
SYMBOL	BOTANICAL NAME/ COMMON PLANT NAME	QUANTITY	SIZE	ROOT	MATURE HEIGHT
JV	JUNIPERUS VIRGINIANA EASTERN RED CEDAR	4	5'-6' HT.	B&B	40'-50' HT.
PG	PICEA GLAUCA WHITE SPRUCE	2	5'-6' HT.	B&B	40'-60' HT.
TS	THUJA STANDISHII X PLICATA 'GREEN GIANT' GREEN GIANT ARBORVITAE	1	5'-6' HT.	B&B	40'-50' HT.

VM2 - COORDINATES

VM2 - VEGETATIVE BUFFER / SCREEN MITIGATION TABLE					
NUMBER	MITIGATION TYPE	LENGTH	LINE/CHORD DIRECTION	START EASTING, NORTHING	END EASTING, NORTHING
L3	TYPE A	60	N47° 09' 38.69"E	E:689813.3783, N:867605.0219	E:689857.7105, N:867646.1304

LEGEND - VM3 PLANTING TEMPLATE TYPE A
LANDSCAPE PLANTING SCHEDULE TOTAL MITIGATION LENGTH = 155 LF

EVERGREEN TREES					
SYMBOL	BOTANICAL NAME/ COMMON PLANT NAME	QUANTITY	SIZE	ROOT	MATURE HEIGHT
JV	JUNIPERUS VIRGINIANA EASTERN RED CEDAR	6	5'-6' HT.	B&B	40'-50' HT.
PG	PICEA GLAUCA WHITE SPRUCE	7	5'-6' HT.	B&B	40'-60' HT.
TS	THUJA STANDISHII X PLICATA 'GREEN GIANT' GREEN GIANT ARBORVITAE		5'-6' HT.	B&B	40'-50' HT.

VM3 - COORDINATES

VM3 - VEGETATIVE BUFFER / SCREEN MITIGATION TABLE					
NUMBER	MITIGATION TYPE	LENGTH	LINE/CHORD DIRECTION	START EASTING, NORTHING	END EASTING, NORTHING
L4	TYPE A	82	N47° 09' 44.78"E	E:689895.7809, N:867681.4667	E:689955.7688, N:867737.0893
L5	TYPE A	73	S45° 33' 57.82"E	E:689955.7688, N:867737.0893	E:690007.9618, N:867685.9175

LEGEND - VM4 PLANTING TEMPLATE TYPE A
LANDSCAPE PLANTING SCHEDULE TOTAL MITIGATION LENGTH = 45 LF

EVERGREEN TREES					
SYMBOL	BOTANICAL NAME/ COMMON PLANT NAME	QUANTITY	SIZE	ROOT	MATURE HEIGHT
JV	JUNIPERUS VIRGINIANA EASTERN RED CEDAR	3	5'-6' HT.	B&B	40'-50' HT.
PG	PICEA GLAUCA WHITE SPRUCE	2	5'-6' HT.	B&B	40'-60' HT.
TS	THUJA STANDISHII X PLICATA 'GREEN GIANT' GREEN GIANT ARBORVITAE	1	5'-6' HT.	B&B	40'-50' HT.

VM4 - COORDINATES

VM4 - VEGETATIVE BUFFER / SCREEN MITIGATION TABLE					
NUMBER	MITIGATION TYPE	LENGTH	LINE/CHORD DIRECTION	START EASTING, NORTHING	END EASTING, NORTHING
L6	TYPE A	45	N80° 37' 10.92"E	E:690591.3788, N:868256.3369	E:690635.7521, N:868263.6672

LEGEND - VM5 PLANTING TEMPLATE TYPE A
LANDSCAPE PLANTING SCHEDULE TOTAL MITIGATION LENGTH = 170 LF

EVERGREEN TREES					
SYMBOL	BOTANICAL NAME/ COMMON PLANT NAME	QUANTITY	SIZE	ROOT	MATURE HEIGHT
JV	JUNIPERUS VIRGINIANA EASTERN RED CEDAR	6	5'-6' HT.	B&B	40'-50' HT.
PG	PICEA GLAUCA WHITE SPRUCE	8	5'-6' HT.	B&B	40'-60' HT.
TS	THUJA STANDISHII X PLICATA 'GREEN GIANT' GREEN GIANT ARBORVITAE	4	5'-6' HT.	B&B	40'-50' HT.

VM5 - COORDINATES

VM5 - VEGETATIVE BUFFER / SCREEN MITIGATION TABLE					
NUMBER	MITIGATION TYPE	LENGTH	LINE/CHORD DIRECTION	START EASTING, NORTHING	END EASTING, NORTHING
L7	TYPE A	66	N37° 06' 09.33"E	E:690654.1539, N:868274.4382	E:690693.7426, N:868326.7788
L8	TYPE A	104	N39° 35' 14.14"E	E:690693.7426, N:868326.7788	E:690760.0450, N:868406.9609

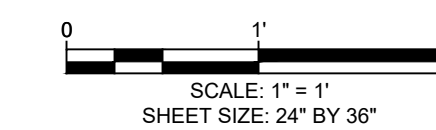

NOTE: THESE PLANS ARE ACCOMPANIED BY SUPPLEMENTAL DOCUMENTS. THESE DOCUMENTS ARE INTERRELATED AND ARE INTENDED TO BE USED TOGETHER. THESE DOCUMENTS ARE INTENDED TO BE USED FOR LOCAL APPROVAL PURPOSES ONLY.
 NOT FOR CONSTRUCTION

GENERAL NOTES:

- USE OF THIS DETAIL/CRITERION IS LIMITED TO ACCESS ROADS USED ON AN OCCASIONAL BASIS ONLY (I.E. PROVIDE ACCESS FOR MOWING, EQUIPMENT REPAIR OR MAINTENANCE, ETC.).
- LIMITED USE PERVIOUS ACCESS ROAD IS LIMITED TO LOW IMPACT IRREGULAR MAINTENANCE ACCESS ASSOCIATED WITH RENEWABLE ENERGY PROJECTS IN NEW YORK STATE.
- REMOVE STUMPS, ROCKS AND DEBRIS AS NECESSARY. FILL VOIDS TO MATCH EXISTING NATIVE SOILS AND COMPACTION LEVEL.
- REMOVED TOPSOIL MAY BE SPREAD IN ADJACENT AREAS AS DIRECTED BY THE PROJECT ENGINEER. COMPACT TO THE DEGREE OF THE NATIVE INSITU SOIL. DO NOT PLACE IN AN AREA THAT IMPEDES STORMWATER DRAINAGE.
- GRADE ROADWAY, WHERE NECESSARY, TO NATIVE SOIL AND DESIRED ELEVATION. MINOR GRADING FOR CROSS SLOPE CUT AND FILL MAY BE REQUIRED.
- REMOVE REFUSE SOILS AS DIRECTED BY THE PROJECT ENGINEER. DO NOT PLACE IN AN AREA THAT IMPEDES STORMWATER DRAINAGE.
- ROADWAY WIDTH ABOVE MINIMUM TO BE DETERMINED BY CLIENT.
- THE LIMITED USE PERVIOUS ACCESS ROAD CROSS SLOPE SHALL BE 2% IN MOST CASES AND SHOULD NOT EXCEED 6%. THE LONGITUDINAL SLOPE OF THE ACCESS DRIVE SHOULD NOT EXCEED 15%.
- THE LIMITED USE PERVIOUS ACCESS ROAD IS NOT INTENDED TO BE UTILIZED FOR CONSTRUCTION WHICH MAY SUBJECT THE ACCESS TO SEDIMENT TRACKING. THIS SPECIFICATION IS TO BE DEVELOPED FOR POST-CONSTRUCTION USE. SOIL RESTORATION PRACTICES MAY BE APPLICABLE TO RESTORE CONSTRUCTION RELATED COMPACTION TO PRE-EXISTING CONDITIONS AND SHOULD BE VERIFIED BY SOIL PENETROMETER READINGS. THE PENETROMETER READINGS SHALL BE COMPARED TO THE RESPECTIVE RECORDED READINGS TAKEN PRIOR TO CONSTRUCTION, EVERY 100 LINEAR FEET ALONG THE PROPOSED ROADWAY.
- TO ENSURE THAT SOIL IS NOT TRACKED ONTO THE LIMITED USE PERVIOUS ACCESS ROAD, IT SHALL NOT BE USED BY CONSTRUCTION VEHICLES TRANSPORTING SOIL, FILL MATERIAL, ETC. IF THE LIMITED USE PERVIOUS ACCESS IS COMPLETED DURING THE INITIAL PHASES OF CONSTRUCTION, A STANDARD NEW YORK STATE STABILIZED CONSTRUCTION ACCESS SHALL BE CONSTRUCTED AND UTILIZED TO REMOVE SEDIMENT FROM CONSTRUCTION VEHICLES AND EQUIPMENT PRIOR TO ENTERING THE LIMITED USE PERVIOUS ACCESS ROAD FROM ANY LOCATION ON, OR OFF SITE. MAINTENANCE OF THE PERVIOUS ACCESS ROAD WILL BE REQUIRED IF SEDIMENT IS OBSERVED WITHIN THE CLEAN STONE.
- THE LIMITED USE PERVIOUS ACCESS ROAD SHALL NOT BE CONSTRUCTED OR USED UNTIL ALL AREAS SUBJECT TO RUNOFF ONTO THE PERVIOUS ACCESS HAVE ACHIEVED FINAL STABILIZATION.
- PROJECTS SHOULD AVOID INSTALLATION OF THE LIMITED USE PERVIOUS ACCESS ROAD IN POORLY DRAINED AREAS. HOWEVER IF NO ALTERNATIVE LOCATION IS AVAILABLE, THE PROJECT SHALL UTILIZE WOVEN GEOTEXTILE MATERIAL AS DETAILED IN FOLLOWING NOTES.
- THE DRAINAGE DITCH IS OFFERED IN THE DETAIL FOR CIRCUMSTANCES WHEN CONCENTRATED FLOW COULD NOT BE AVOIDED. THE INTENTION OF THIS DESIGN IS TO MINIMIZE ALTERATIONS TO HYDROLOGY, HOWEVER WHEN DEALING WITH 5%-15% GRADES NOT PARALLEL TO THE CONTOUR, A ROADSIDE DITCH MAY BE REQUIRED. THE NYS STANDARDS AND SPECIFICATIONS FOR EROSION AND SEDIMENT CONTROLS FOR GRASSSED WATERWAYS AND VEGETATED WATERWAYS ARE APPLICABLE FOR SIZING AND STABILIZATION. DIMENSIONS FOR THE GRASSSED WATERWAY SPECIFICATION WOULD BE DESIGNED FOR PROJECT SPECIFIC HYDROLOGIC RUNOFF CALCULATIONS, AND A SEPARATE DETAIL FOR THE SPECIFIC GRASSSED WATERWAY WOULD BE INCLUDED IN THIS PRACTICE. RUNOFF DISCHARGES WILL BE SUBJECT TO THE OUTLET REQUIREMENTS OF THE REFERENCED STANDARD. INCREASED POST-DEVELOPMENT RUNOFF FROM THE ASSOCIATED ROADSIDE DITCH MAY REQUIRE ADDITIONAL PRACTICES TO ATTENUATE RUNOFF TO PRE-DEVELOPMENT CONDITIONS.
- IF A ROADSIDE DITCH IS NOT UTILIZED TO CAPTURE RUNOFF FROM THE ACCESS ROAD, THE PERVIOUS ACCESS ROAD WILL HAVE A WELL-ESTABLISHED PERENNIAL VEGETATIVE COVER WHICH SHALL CONSIST OF UNIFORM VEGETATION (I.E. BUFFER), 20 FEET WIDE AND PARALLEL TO THE DOWN GRADIENT SIDE OF THE ACCESS ROAD. POST-CONSTRUCTION OPERATION AND MAINTENANCE PRACTICES WILL MAINTAIN THIS VEGETATIVE COVER TO ENSURE FINAL STABILIZATION FOR THE LIFE OF THE ACCESS ROAD.
- THE DESIGN PROFESSIONAL MUST ACCOUNT FOR THE LIMITED USE PERVIOUS ACCESS ROAD IN THEIR SITE ASSESSMENT/HYDROLOGY ANALYSIS. IF THE HYDROLOGY ANALYSIS SHOWS THAT THE HYDROLOGY HAS BEEN ALTERED FROM PRE- TO POST-DEVELOPMENT CONDITIONS (SEE APPENDIX A OF GP-0-20-001 FOR THE DEFINITION OF "ALTER THE HYDROLOGY..."), THE DESIGN MUST INCLUDE THE NECESSARY DETENTION/RETENTION PRACTICES TO ATTENUATE THE RATES (10 AND 100 YEAR EVENTS) TO PRE-DEVELOPMENT CONDITIONS.

GEOGRID MATERIAL NOTES:

- THE GEOGRID, OR COMPARABLE PRODUCT, IS INTENDED FOR USE FOR ALL CONDITIONS, IN ORDER TO ASSIST IN MATERIAL SEPARATION FROM NATIVE SOILS AND PRESERVE ACCESS LOADS.
- GRAVEL FILL MATERIAL SHALL CONSIST OF 1-2" CLEAN, DURABLE, SHARP-ANGLED CRUSHED STONE OF UNIFORM QUALITY MEETING THE SPECIFICATIONS OF NYS DOT ITEM 703-02. SIZE DESIGNATION 3-5 OF TABLE 703-4. STONE MAY BE PLACED IN FRONT OF, AND SPREAD WITH, A TRACKED VEHICLE. GRAVEL SHALL NOT BE COMPACTED.
- GEOGRID SHALL BE MIRAFI BXG110 OR APPROVED EQUAL. GEOGRID SHALL BE DESIGNED BASED ON EXISTING SOIL CONDITIONS AND PROPOSED HAUL ROAD SLOPES.
- IF MORE THAN ONE ROLL WIDTH IS REQUIRED, ROLLS SHOULD OVERLAP A MINIMUM OF NINE INCHES.
- REFER TO MANUFACTURER'S SPECIFICATION FOR PROPER TYING AND CONNECTIONS.
- LIMITED USE PERVIOUS ACCESS ROAD SHALL BE TOP DRESSED AS REQUIRED WITH ONLY 1-2" CRUSHED STONE MEETING NYS DOT ITEM 703-02 SPECIFICATIONS.

BASIS OF DESIGN: TENCATE MIRAFI BXG110 GEOGRIDS; 365 SOUTH HOLLAND DRIVE, PENDERGRASS, GA; 800-685-9990 OR 706-693-2226; WWW.MIRAFI.COM

GEOWEB MATERIAL NOTES:

- THE GEOWEB, OR COMPARABLE PRODUCT, IS SUGGESTED FOR USE ON ROAD PROFILES EXCEEDING 10%. THE GEOWEB PRODUCT IS INTENDED TO LIMIT SHIFTING STONE MATERIAL DURING USE.
- INSTALLATION TO BE COMPLETED IN ACCORDANCE WITH MANUFACTURER'S SPECIFICATIONS.
- WHERE REQUIRED, A NATIVE SOIL WEDGE SHALL BE PLACED TO ACCOMMODATE ROAD CROSS SLOPE OF 2%. NATIVE SOIL SHALL BE COMPACTED TO MATCH EXISTING SOIL CONDITIONS.
- GRAVEL FILL MATERIAL SHALL CONSIST OF 1-2" CLEAN, DURABLE, SHARP-ANGLED CRUSHED STONE OF UNIFORM QUALITY MEETING THE SPECIFICATIONS OF NYS DOT ITEM 703-02. SIZE DESIGNATION 3-5 OF TABLE 703-4. STONE MAY BE PLACED IN FRONT OF, AND SPREAD WITH, A TRACKED VEHICLE. GRAVEL SHALL NOT BE COMPACTED.
- GEOWEB SYSTEM SHALL BE PRESTO GEOSYSTEM GEOWEB OR APPROVED EQUAL. GEOWEB SHALL BE DESIGNED BASED ON EXISTING SOIL CONDITIONS AND PROPOSED HAUL ROAD SLOPES.
- LIMITED USE PERVIOUS ACCESS ROAD SHALL BE TOP DRESSED AS REQUIRED WITH ONLY 1-2" CRUSHED STONE, SIZE 3A, MEETING NYS DOT ITEM 703-02 SPECIFICATIONS.
- THE TOP EDGES OF ADJACENT CELL WALLS SHALL BE FLUSH WHEN CONNECTING. ALIGN THE I-SLOTS FOR INTERLEAF AND END TO END CONNECTIONS. THE GEOWEB PANELS SHALL BE CONNECTED WITH ATRA KEYS AT EACH INTERLEAF AND END TO END CONNECTIONS. REFER TO MANUFACTURER'S SPECIFICATION FOR PROPER INSTALLATION, TYING, ANCHORING, AND CONNECTIONS.

BASIS OF DESIGN: PRESTO GEOSYSTEMS GEOWEB; 670 NORTH PERKINS STREET, APPLETON, WI; 800-548-3424 OR 920-738-1222; INFO@PRESTOGEOWEB.COM; WWW.PRESTOGEOWEB.COM

WOVEN GEOTEXTILE MATERIAL NOTES:

- SPECIFIED GEOTEXTILE WILL ONLY BE UTILIZED IN PLACID SOILS. PLACID SOILS CONSIST OF POORLY DRAINED SOILS COMPOSED OF FINELY TEXTURED PARTICLES AND ARE PRONE TO RUTTING. PLACID SOILS ARE TYPICALLY PRESENT IN LOW-LYING AREAS WITH HYDROLOGIC SOILS GROUP (HSG) OF C OR D, OR AS SPECIFIED BY AN ENGINEER, ENVIRONMENTAL SCIENTIST, SOIL SCIENTIST, OR GEOTECHNICAL DATA.
- THE CONCERN FOR POTENTIAL REDUCTION OF NATIVE INFILTRATION RATES DUE TO THE GEOTEXTILE MATERIAL WOULD NOT BE A SIGNIFICANT CONCERN IN POORLY DRAINED SOILS WHERE SEGREGATION OF PERVIOUS STONE AND NATIVE MATERIALS IS CRUCIAL FOR LONG TERM OPERATION AND MAINTENANCE.

BASIS OF DESIGN: TENCATE MIRAFI RSI-SERIES WOVEN GEOSYNTHETICS; 365 SOUTH HOLLAND DRIVE, PENDERGRASS, GA; 800-685-9990 OR 706-693-2226; WWW.MIRAFI.COM

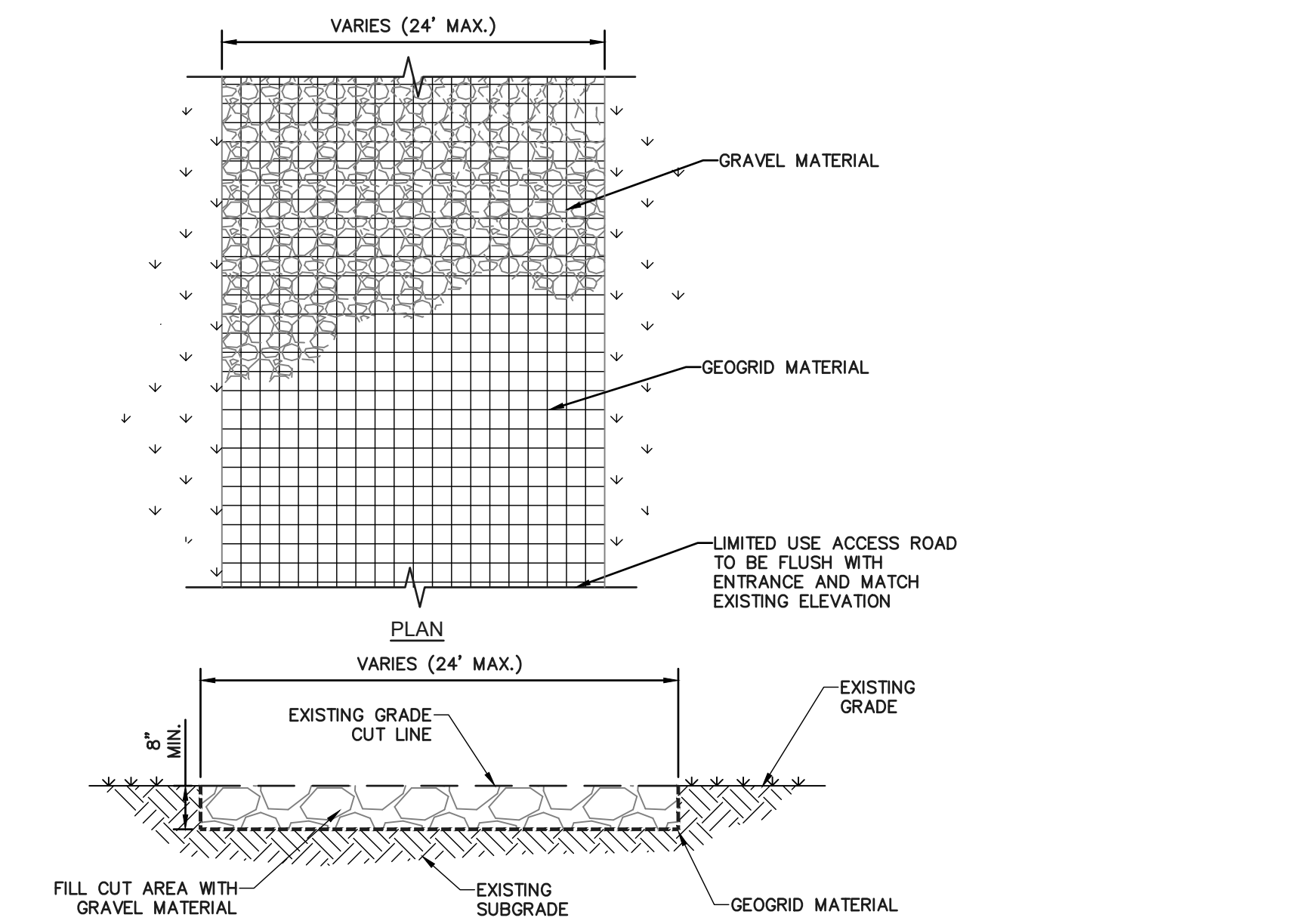

LIMITED USE PERVIOUS ACCESS ROAD - 0% TO 10% SLOPES
NOT TO SCALE

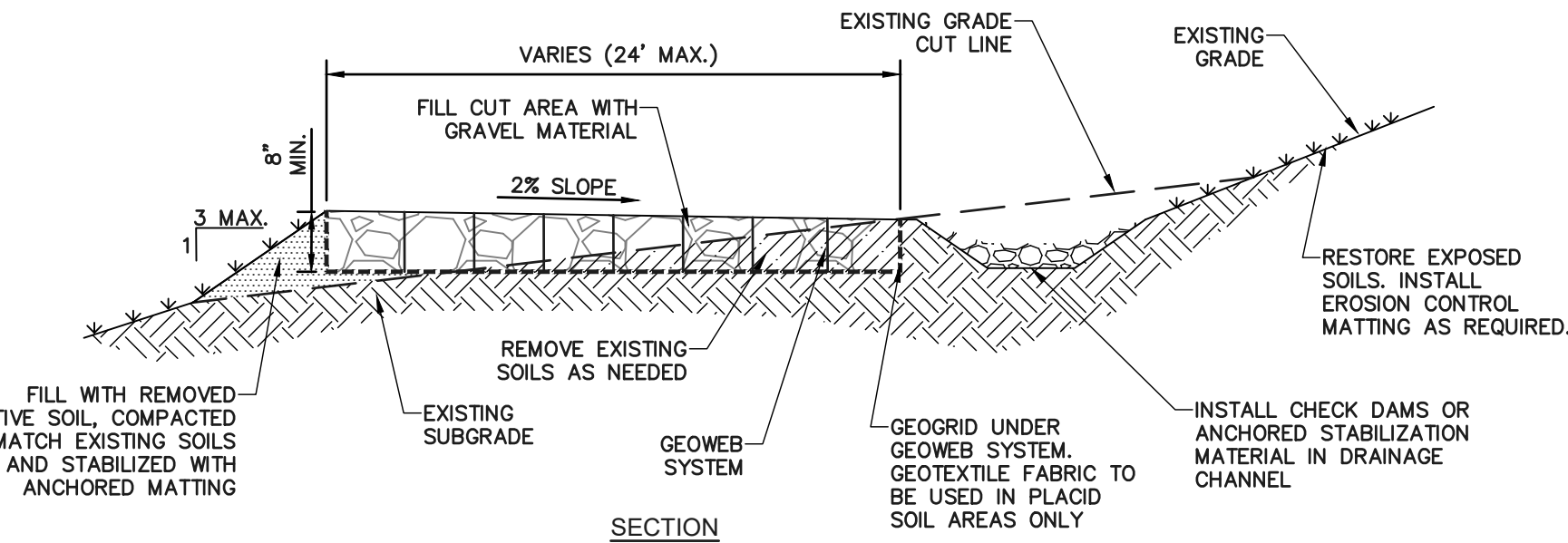

NOTE:
1. THE ROADSIDE DITCH SHALL BE DESIGNED IN ACCORDANCE WITH THE NEW YORK STATE STANDARDS AND SPECIFICATIONS FOR EROSION AND SEDIMENT CONTROLS FOR GRASSSED AND VEGETATED WATERWAYS. ADDITIONAL DETAILS WILL BE PROVIDED SPECIFIC TO THE SITE DESIGN.

LIMITED USE PERVIOUS ACCESS ROAD - 10% AND GREATER SLOPES WITH DITCH
NOT TO SCALE

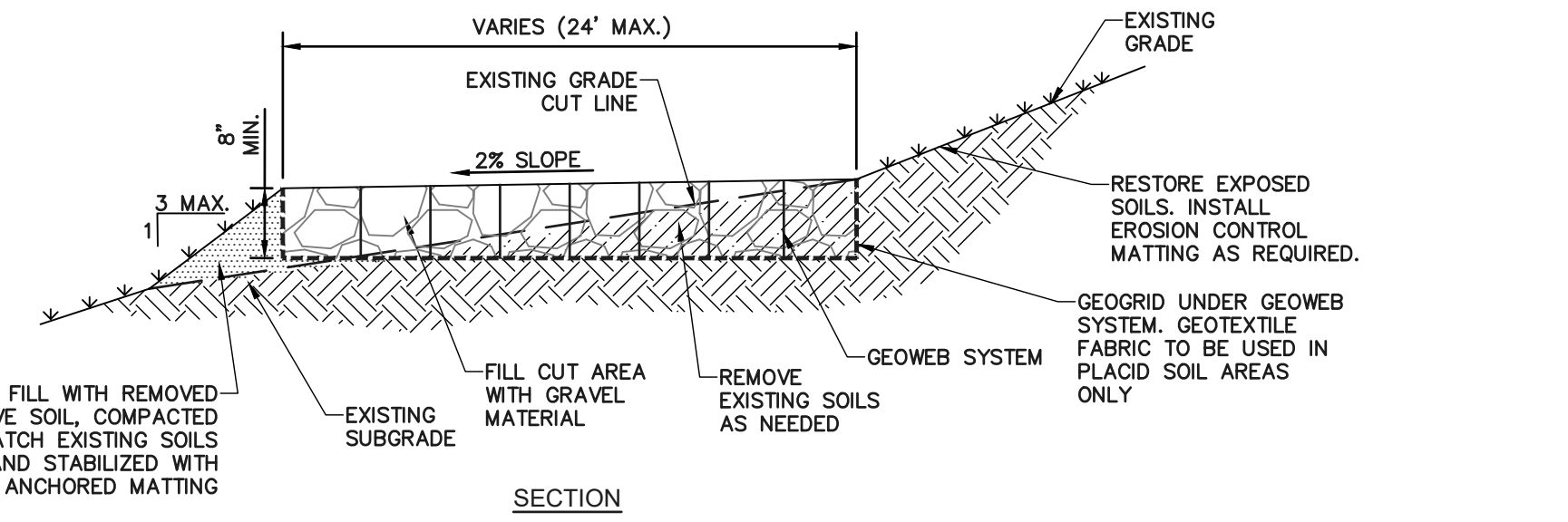
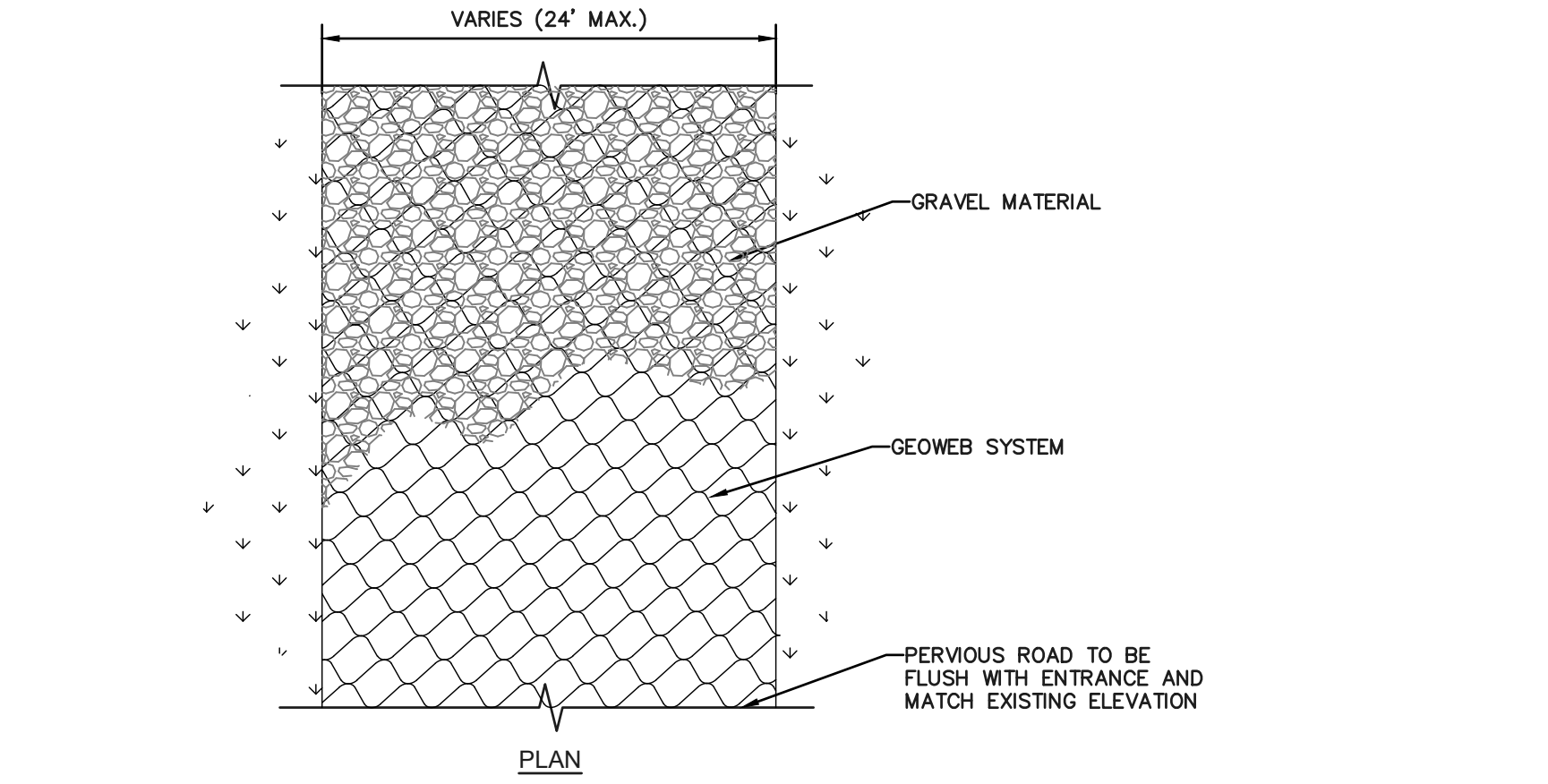

LIMITED USE PERVIOUS ACCESS ROAD - 10% AND GREATER SLOPES
NOT TO SCALE

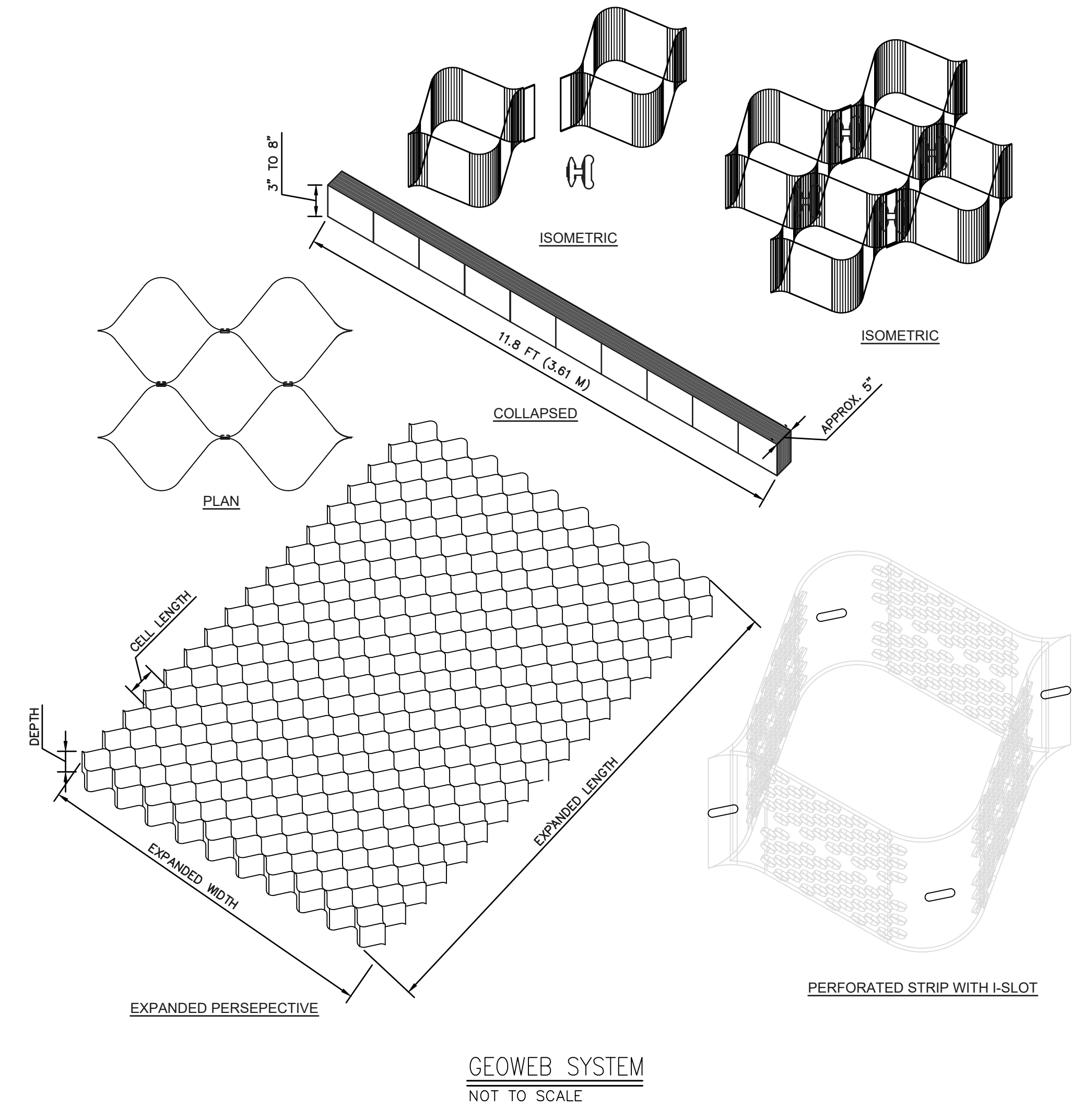

NOTE: UNDER NEW YORK STATE EDUCATION LAW ARTICLE 145 (ENGINEERING), SECTION 7209 (2), IT IS A VIOLATION FOR ANY PERSON, UNLESS ACTING UNDER THE DIRECTION OF A LICENSED PROFESSIONAL ENGINEER, TO ALTER THIS DOCUMENT.

NOTE: THESE PLANS ARE ACCOMPANIED BY A SUPPLEMENTAL DOCUMENTS. THESE DOCUMENTS ARE INTERRELATED AND ARE INTENDED TO BE USED TOGETHER. THESE DOCUMENTS ARE INTENDED TO BE USED FOR LOCAL APPROVAL PURPOSES ONLY.
NOT FOR CONSTRUCTION

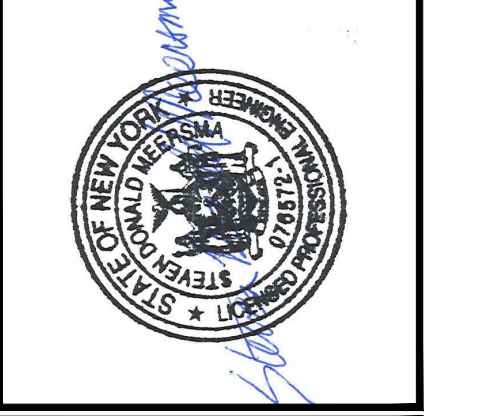

Revisions:	
No.	Date:

Drawn by:
A. REXROAT
Checked by:
S. MEERSMA
Approved by:
C. DUNCAN

SCS DELL 014136 YORKTOWN, LLC
DELL AVENUE SOLAR FARM
FIXED-TILT GROUND MOUNT SOLAR ENERGY SYSTEM
DELL AVENUE, YORKTOWN, NEW YORK 10514

Contract No:
431302
Scale:
AS SHOWN
Date:
JUNE 14, 2022
Sheet:
DETAIL SHEET 1

Drawing No:
D-101

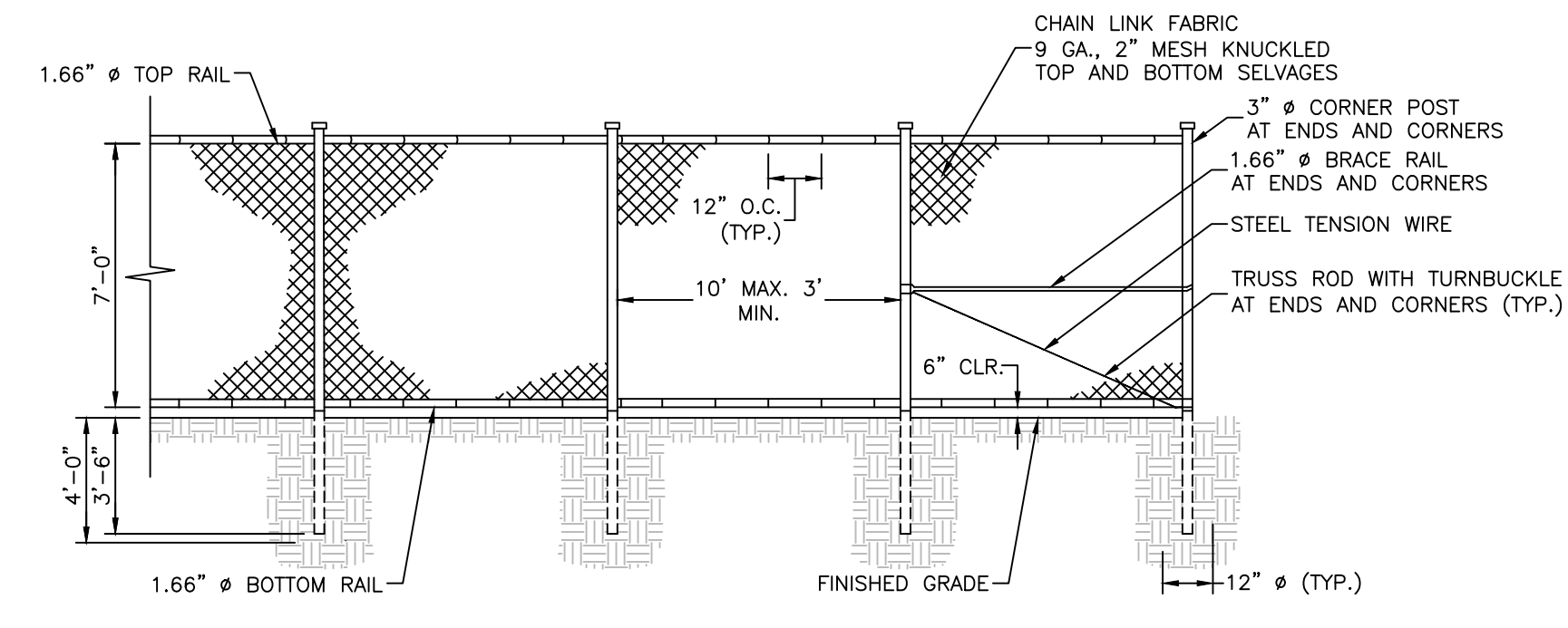

FENCE INSTALLATION NOTES
 • THE OPENINGS IN THE LINKS SHALL BE A MAXIMUM OF 2"

CHAIN LINK FENCE DETAIL
 NOT TO SCALE

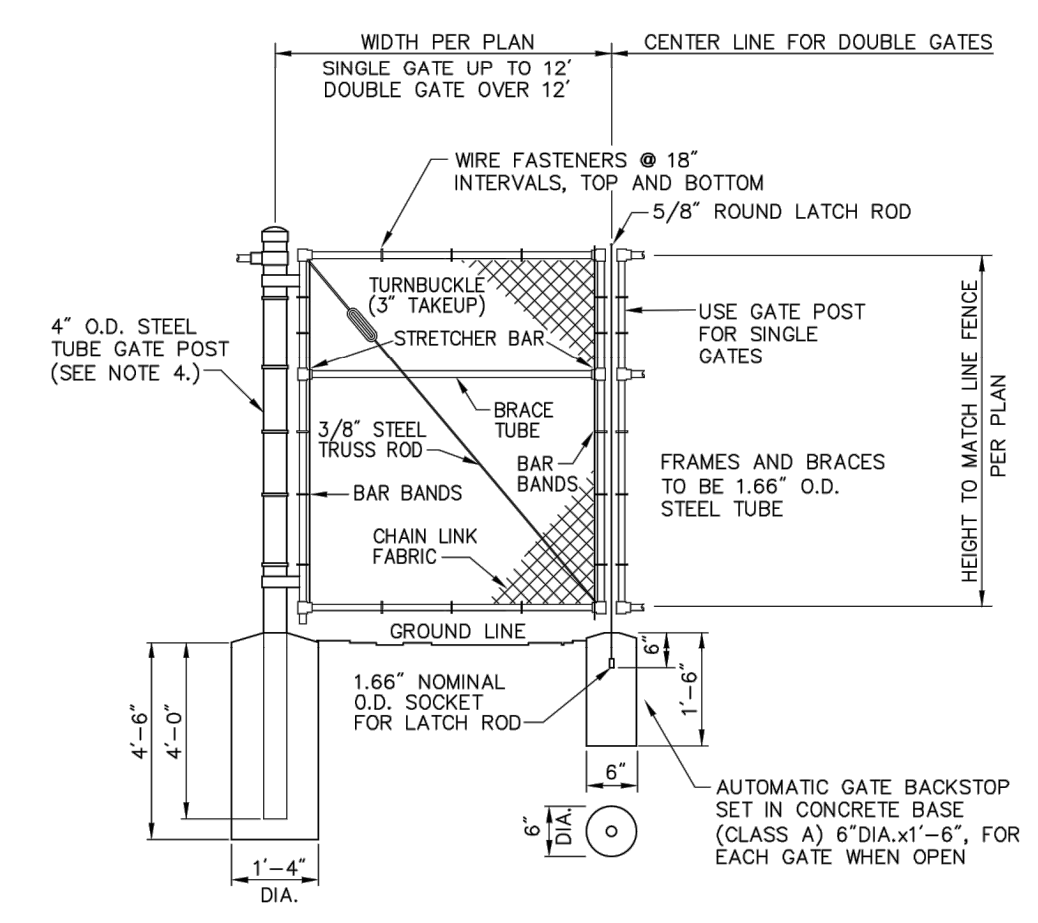

- Notes:**
- CHAIN LINK FABRIC FOR GATES TO BE THE SAME AS REQUIRED FOR FENCE.
 - GATE POST BASE—PORTLAND CEMENT CONCRETE (3000 PSI).
 - FENCE FABRIC, POSTS, FRAMEWORKS, AND HARDWARE SHALL BE GALVANIZED STEEL WITH COLORED VINYL COATING, COLOR PER OWNER.
 - GATE POSTS TO BE USED ON EACH SIDE OF SINGLE AND DOUBLE GATE OPENINGS.

CHAIN LINK GATE DETAIL
 NOT TO SCALE

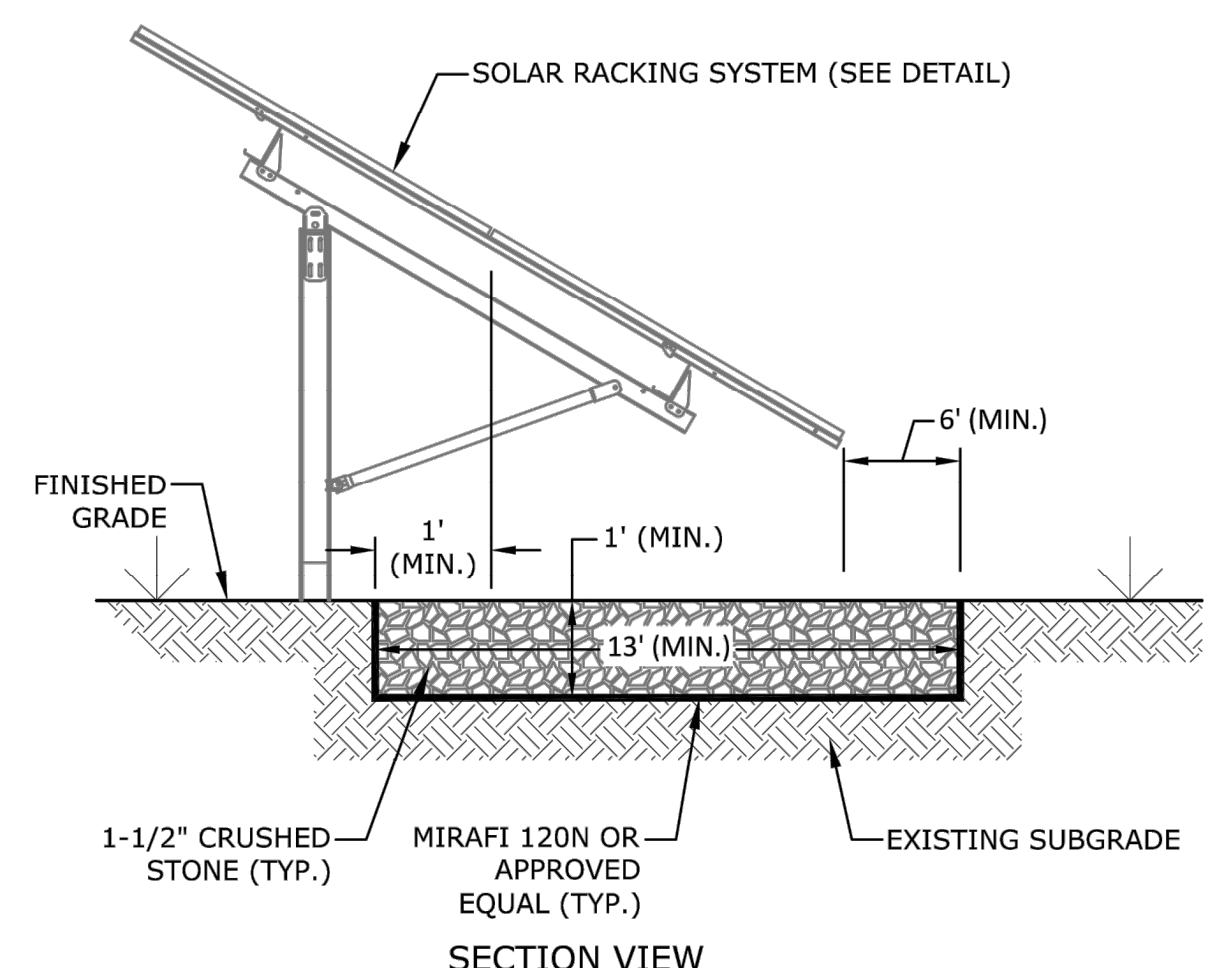

- NOTES:**
- CONSTRUCT AT GRADE LEVEL SPREADER ON ZERO PERCENT GRADE TO INSURE UNIFORM SPREADING OF RUNOFF (CONVERTING CHANNEL FLOW TO SHEET FLOW).
 - AT GRADE LEVEL SPREADER SHALL BE CONSTRUCTED ON UNDISTURBED SOIL (NOT ON FILL).
 - STORM RUNOFF CONVERTED TO SHEET FLOW SHALL OUTLET ONTO STABILIZED AREAS. WATER SHALL NOT BE RECONCENTRATED IMMEDIATELY BELOW THE POINT OF DISCHARGE.

LEVEL SPREADER
 NOT TO SCALE

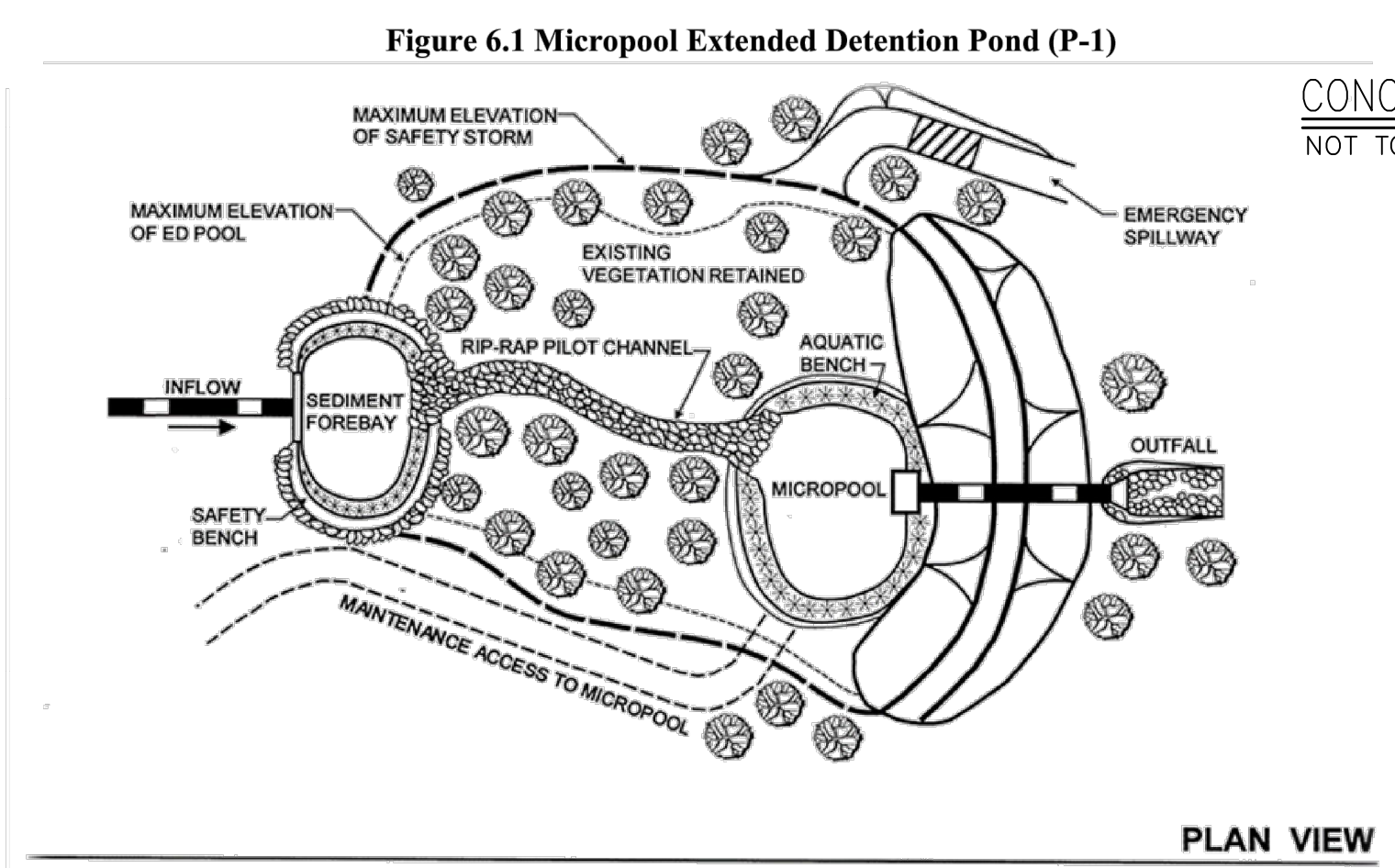

CONCRETE PAD (ELECTRICAL EQUIP. TYP.)
 NOT TO SCALE

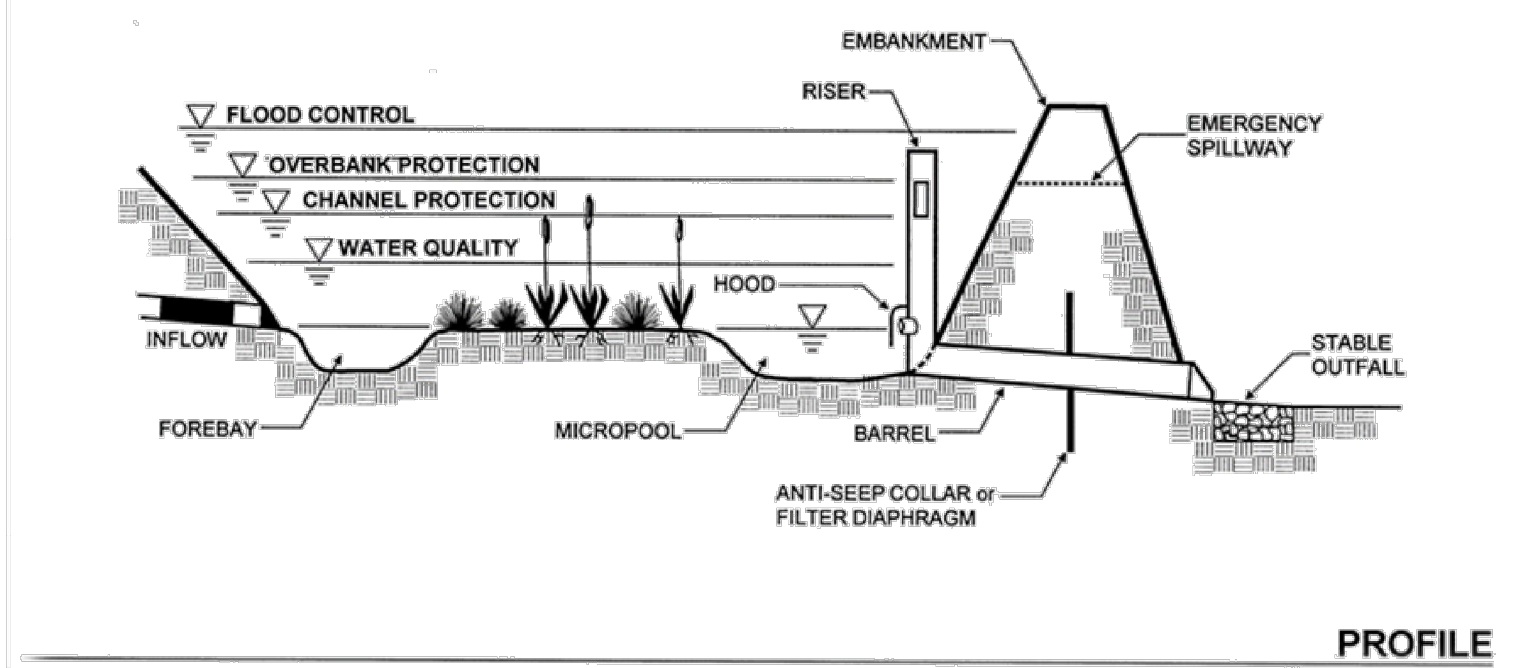

PROFILE

MICROPOOL EXTENDED DETENTION POND
 NOT TO SCALE

- MICROPOOL — PLANTINGS**
- PLANTINGS WILL BE BASED ON APPENDIX H IN THE NYS STORMWATER DESIGN MANUAL. NATIVE ZONE 1 AND ZONE 2 PLANTINGS ON THE AQUATIC BENCH, BETWEEN APPROXIMATELY ELEVATIONS 237 FT AND 239 FT. NO WOODY PLANTS WILL BE PLANTED IN THE INFLOW SIDE OF THE MICROPOOL. PLANTINGS WILL BE DIVERSE AND RANDOM TO RESEMBLE NATURAL PLANT LAYOUTS.

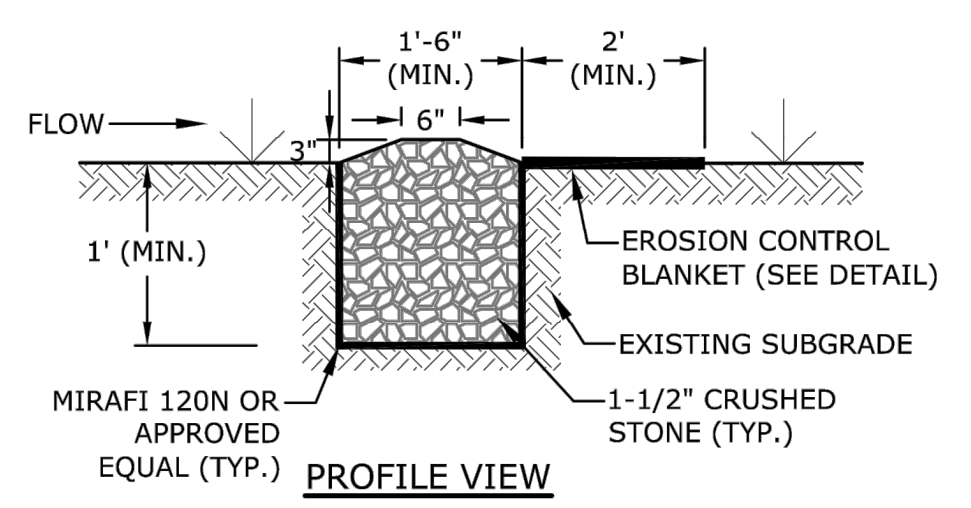

PROFILE VIEW

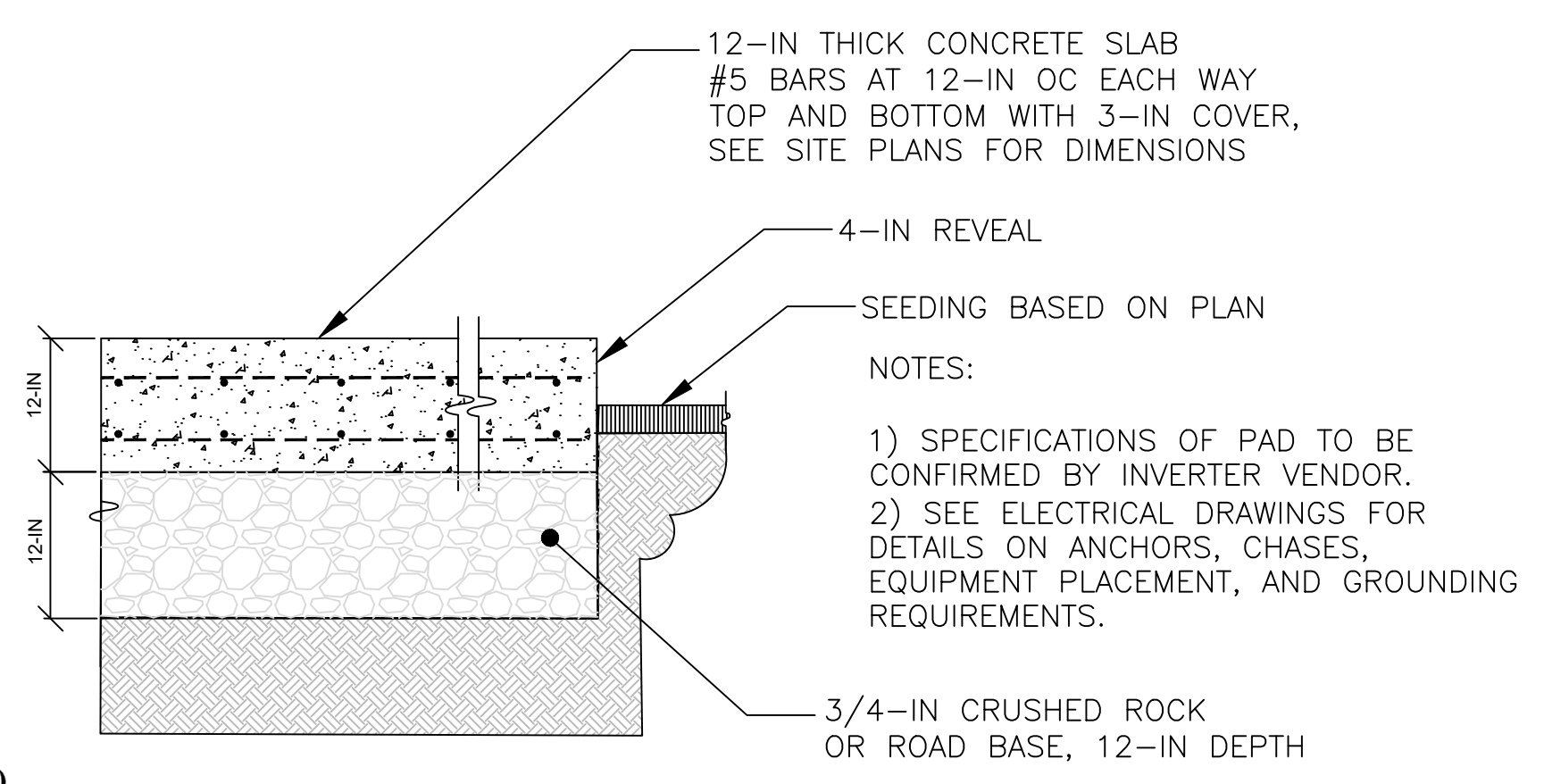

- NOTES:**
- SPECIFICATIONS OF PAD TO BE CONFIRMED BY INVERTER VENDOR.
 - SEE ELECTRICAL DRAWINGS FOR DETAILS ON ANCHORS, CHASES, EQUIPMENT PLACEMENT, AND GROUNDING REQUIREMENTS.

CONCRETE PAD (ELECTRICAL EQUIP. TYP.)
 NOT TO SCALE

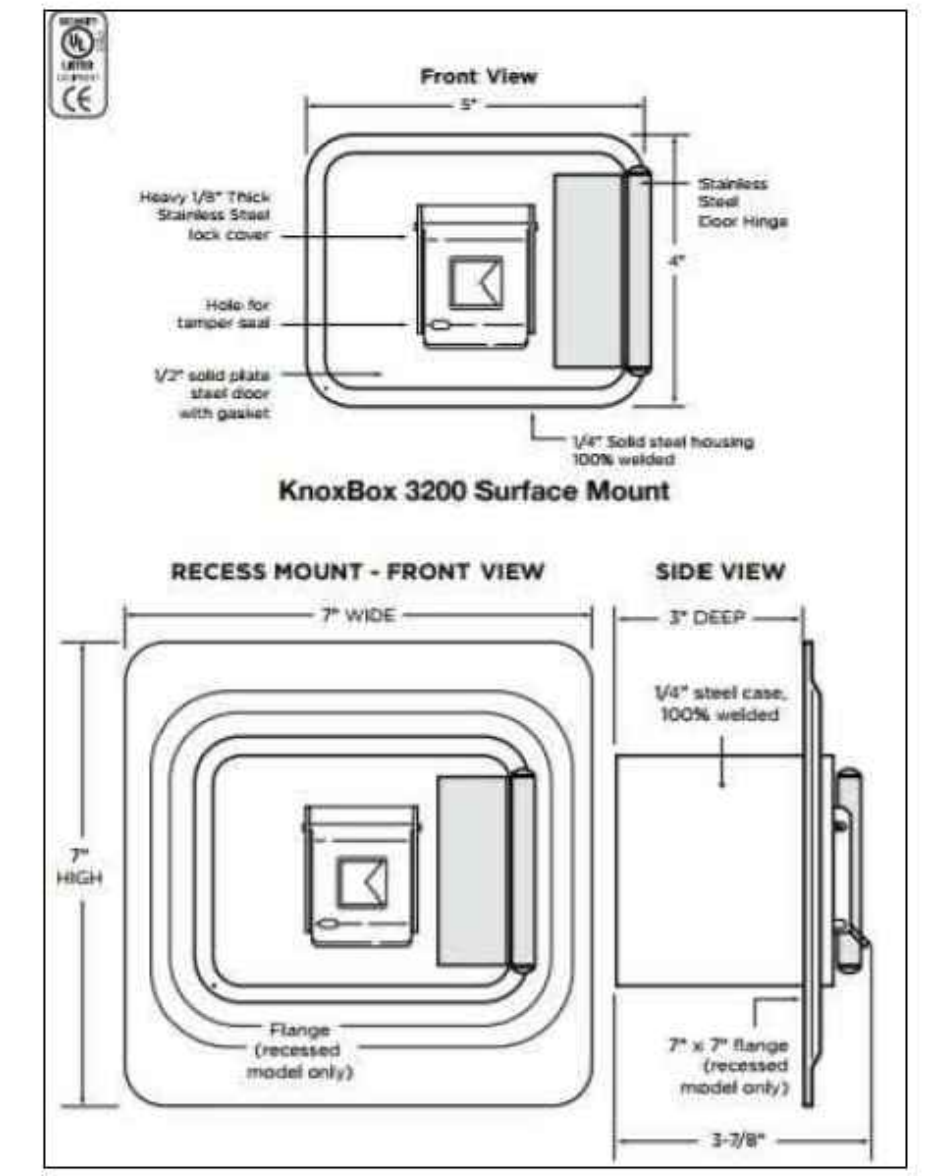

KNOX BOX
 NOT TO SCALE

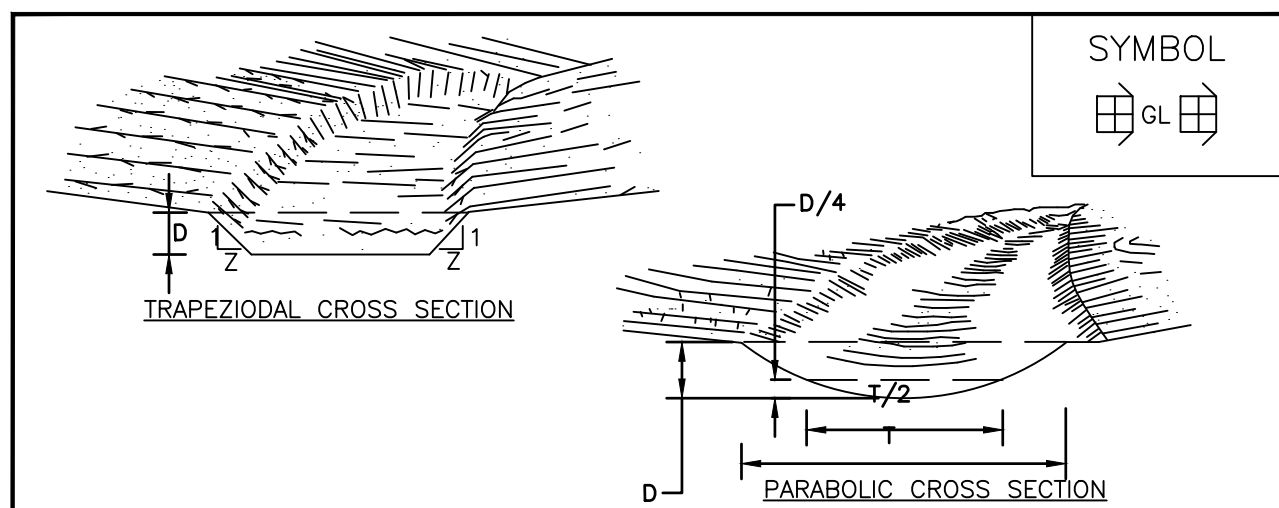

CONSTRUCTION SPECIFICATIONS

- ALL TREES, BRUSH, STUMPS, OBSTRUCTIONS, AND OTHER OBJECTIONABLE MATERIAL SHALL BE REMOVED AND DISPOSED OF SO AS NOT TO INTERFERE WITH THE PROPER FUNCTIONING OF THE WATERWAY.
- THE WATERWAY SHALL BE EXCAVATED OR SHAPED TO LINE, GRADE, AND CROSS SECTION AS REQUIRED TO MEET THE CRITERIA SPECIFIED HEREIN, AND BE FREE OF BANK PROJECTIONS OR OTHER IRREGULARITIES WHICH WILL IMPEDE NORMAL FLOW.
- FILLS SHALL BE COMPACTED AS NEEDED TO PREVENT UNEQUAL SETTLEMENT THAT WOULD CAUSE DAMAGE IN THE COMPLETE WATERWAY.
- ALL EARTH REMOVED AND NOT NEEDED IN CONSTRUCTION SHALL BE SPREAD OR DISPOSED OF SO THAT IT WILL NOT INTERFERE WITH THE FUNCTIONING OF THE WATERWAY.
- STABILIZATION SHALL BE DONE ACCORDING TO THE APPROPRIATE STANDARD AND SPECIFICATIONS FOR VEGETATIVE PRACTICES.
 - FOR DESIGN VELOCITIES OF LESS THAN 3.5 FT. PER SEC., SEEDING AND MULCHING MAY BE USED FOR THE ESTABLISHMENT OF THE VEGETATION. IT IS RECOMMENDED THAT, WHEN CONDITIONS PERMIT, TEMPORARY WATERWAYS OR OTHER MEANS SHOULD BE USED TO PREVENT WATER FROM ENTERING THE WATERWAY DURING THE ESTABLISHMENT OF THE VEGETATION.
 - FOR DESIGN VELOCITIES OF MORE THAN 3.5 FT. PER SEC., THE WATERWAY SHALL BE STABILIZED WITH SOG, WITH SEEDING PROTECTED BY JUTE OR EXCELISIOR MATTING OR WITH SEEDING AND MULCHING INCLUDING TEMPORARY DIVERSION OF THE WATER UNTIL THE VEGETATION IS ESTABLISHED.
 - STRUCTURAL — VEGETATIVE PROTECTION
 - SUBSURFACE DRAIN FOR BASE FLOW SHALL BE CONSTRUCTED AS SHOWN ON THE STANDARD DRAWING AND AS SPECIFIED IN THE STANDARD AND SPECIFICATIONS FOR SUBSURFACE DRAIN.

GRASSED WATERWAY

NOTE: UNDER NEW YORK STATE EDUCATION LAW ARTICLE 145 (ENGINEERING), SECTION 7209 (2), IT IS A VIOLATION FOR ANY PERSON, UNLESS ACTING UNDER THE DIRECTION OF A LICENSED PROFESSIONAL ENGINEER, TO ALTER THIS DOCUMENT.

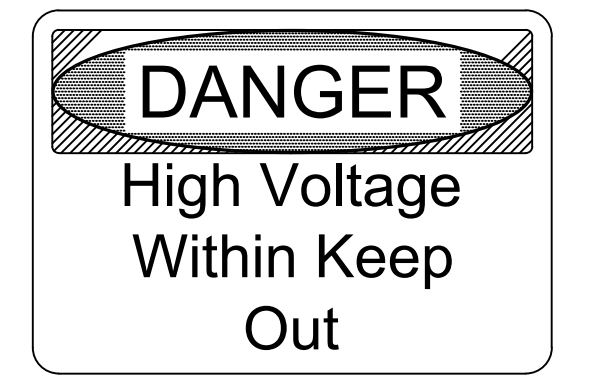
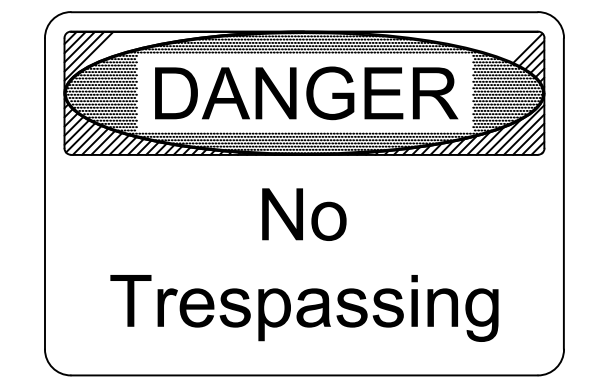

- NOTES:**
- SIGNS SHALL CONFORM TO THE 2013 OSHA AND ANSI REQUIREMENTS.
 - SIGNS SHALL BE 20" WIDE BY 14" HIGH.
 - SIGNS SHALL HAVE A MOUNTING HEIGHT OF BETWEEN 45 TO 66 INCHES.
 - SIGN PANELS SHALL BE 10 GAUGE ALUMINUM WITH HIGH VISIBILITY REFLECTIVE SHEETING.
 - MOUNT A SET OF SIGNS NOT MORE THAN EVERY 100 FEET ALONG PERIMETER FENCING.

FENCE WARNING SIGNS
 NOT TO SCALE

DELL AVENUE
 YORKTOWN, NY
 SITE OPERATOR: SOL SYSTEMS, LLC.
 SITE OPERATOR NUMBER: 202.519.3375

CONTACT PLAQUE
 NOT TO SCALE

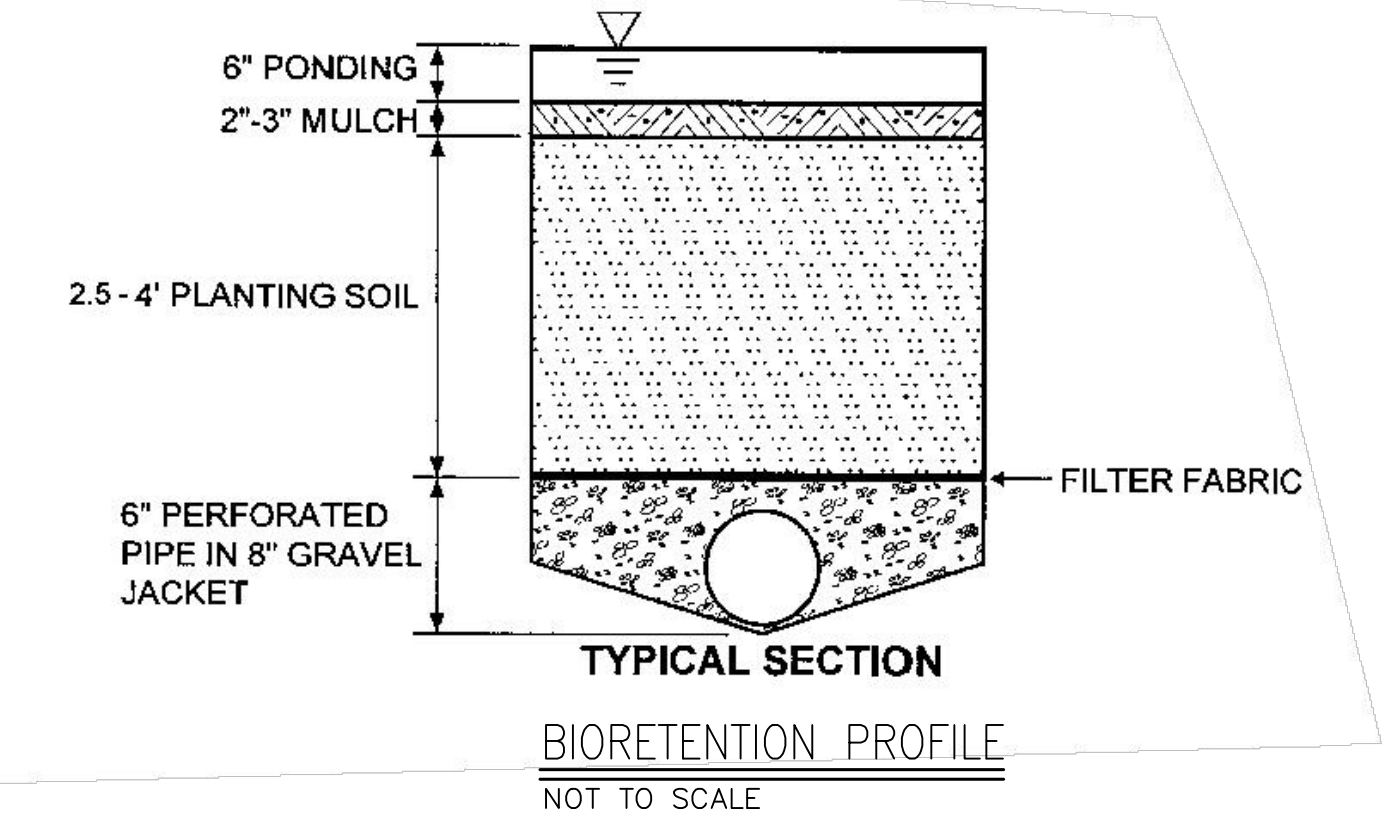

TYPICAL SECTION
BIORETENTION PROFILE
 NOT TO SCALE

- BIORETENTION — SOIL SPECIFICATIONS**
- SOIL MEDIA COMPOSITION SHALL BE A UNIFORM MIXTURE OF 50% TO 70% SAND (ASTM C-33) AND 50% TO 30% ORGANIC MATERIAL (TOPSOIL) BY VOLUME. THE MEDIA BLEND SHALL CONTAIN AVERAGE OF 5% ORGANIC MATTER SUCH AS COMPOST OR PEAT, AND BE FREE OF STONES, STUMPS, ROOTS, WOODY MATERIAL OVER 2" IN DIAMETER, ANIMAL WASTE, BRUSH, OR SEEDS FROM NOXIOUS WEEDS.
 - THE SOIL MEDIA SHALL CONTAIN LESS THAN 5% CLAY, HAVE A pH RANGE OF 5.2 TO 7.6, AND A LOW PHOSPHORUS INDEX (BETWEEN 0 AND 25). A PERMEABILITY OF AT LEAST 1.0 FEET PER DAY (0.5"/HR) IS REQUIRED. ONLY COMPOST OR PEAT SHALL BE USED AS A SOIL AMENDMENT TO INCREASE ORGANIC CONTENT AS REQUIRED.
 - THE SOIL MEDIA SHALL BE TESTED FOR TOTAL PHOSPHORUS CONTENT AT A QUALIFIED LABORATORY, ONE THAT IS CERTIFIED BY THE NEW YORK STATE DEPARTMENT OF HEALTH (NYSDOH) ENVIRONMENTAL LABORATORY APPROVAL PROGRAM (ELAP) TO TEST SOIL FOR TOTAL PHOSPHORUS.
 - ACCEPTANCE OF THE SOIL MEDIA SHALL BE BASED UPON THE CONTRACTOR OR SUPPLIER PROVIDING TO THE ENGINEER COPIES OF TESTING RESULTS CERTIFYING THAT THE SAND GRADATION, TOPSOIL GRADATION, ORGANIC MATTER CONTENT, pH, PERMEABILITY, AND TOTAL PHOSPHORUS CONTENT ALL CONFORM TO THE STATED REQUIREMENTS.

- BIORETENTION — PLANTINGS**
- PLANTINGS WILL CONSIST OF TWO DIFFERENT ZONES BASED ON APPENDIX H IN THE NYS STORMWATER DESIGN MANUAL. ON THE BOTTOM OF THE BIO-AREA TO APPROXIMATELY 0.75 FT FROM THE BOTTOM, THERE WILL BE NATIVE ZONE 3 PLANTINGS. FROM THE TOP OF ZONE 3 PLANTINGS TO THE EDGE OF THE BIO-AREA GRADING, THERE WILL BE ZONE 5 PLANTINGS. OUTSIDE OF THE BIO-AREA, THERE WILL BE EXISTING VEGETATION COVER ON THE DOWN SLOPE SIDE AND MEADOW GRASSES ON THE UP-SLOPE SIDE. NO WOODY PLANTS WILL BE PLANTED IN THE UP-SLOPE/INFLOW SIDE OF THE BIO-AREA. PLANTINGS WILL BE DIVERSE AND RANDOM TO RESEMBLE NATURAL PLANT LAYOUTS.

NOTE: THESE PLANS ARE ACCOMPANIED BY SUPPLEMENTAL DOCUMENTS. THESE DOCUMENTS ARE INTERRELATED AND ARE INTENDED TO BE USED TOGETHER. THESE DOCUMENTS ARE INTENDED TO BE USED FOR LOCAL APPROVAL PURPOSES ONLY.
 NOT FOR CONSTRUCTION

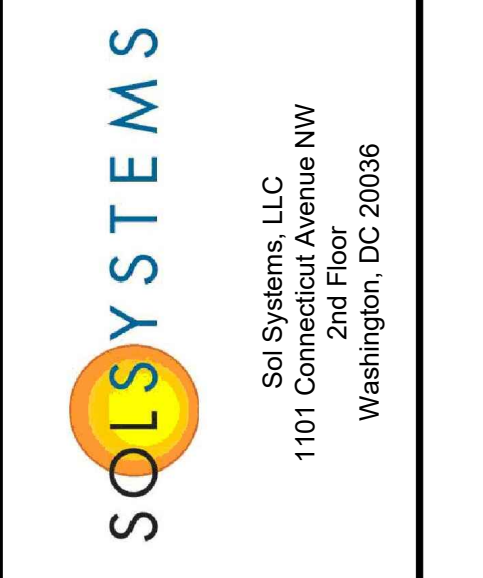
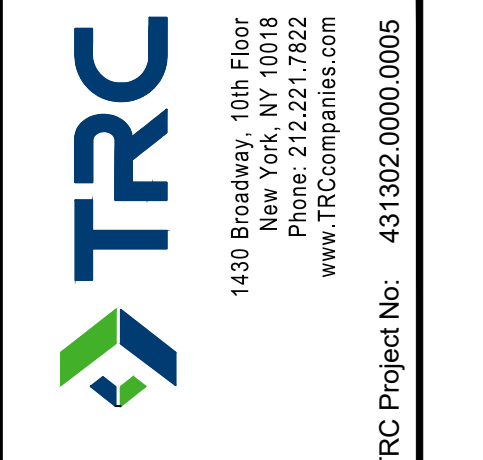

Revisions:	
No.	Date:
1	SEPTEMBER 21, 2022

Drawn by:
 A. REXROAT
 Checked by:
 S. MEERSMA
 Approved by:
 C. DUNCAN

SCS DELL 014136 YORKTOWN, LLC
 DELL AVENUE SOLAR FARM
 FIXED-TILT GROUND MOUNT SOLAR ENERGY SYSTEM
 DELL AVENUE, YORKTOWN, NEW YORK 10514

Contract No:
 431302
 Scale:
 AS SHOWN
 Date:
 AUGUST 30, 2022
 Sheet:
 DETAIL SHEET 2

Drawing No:
 D-102

TRC Project No: 431302.0000.0005

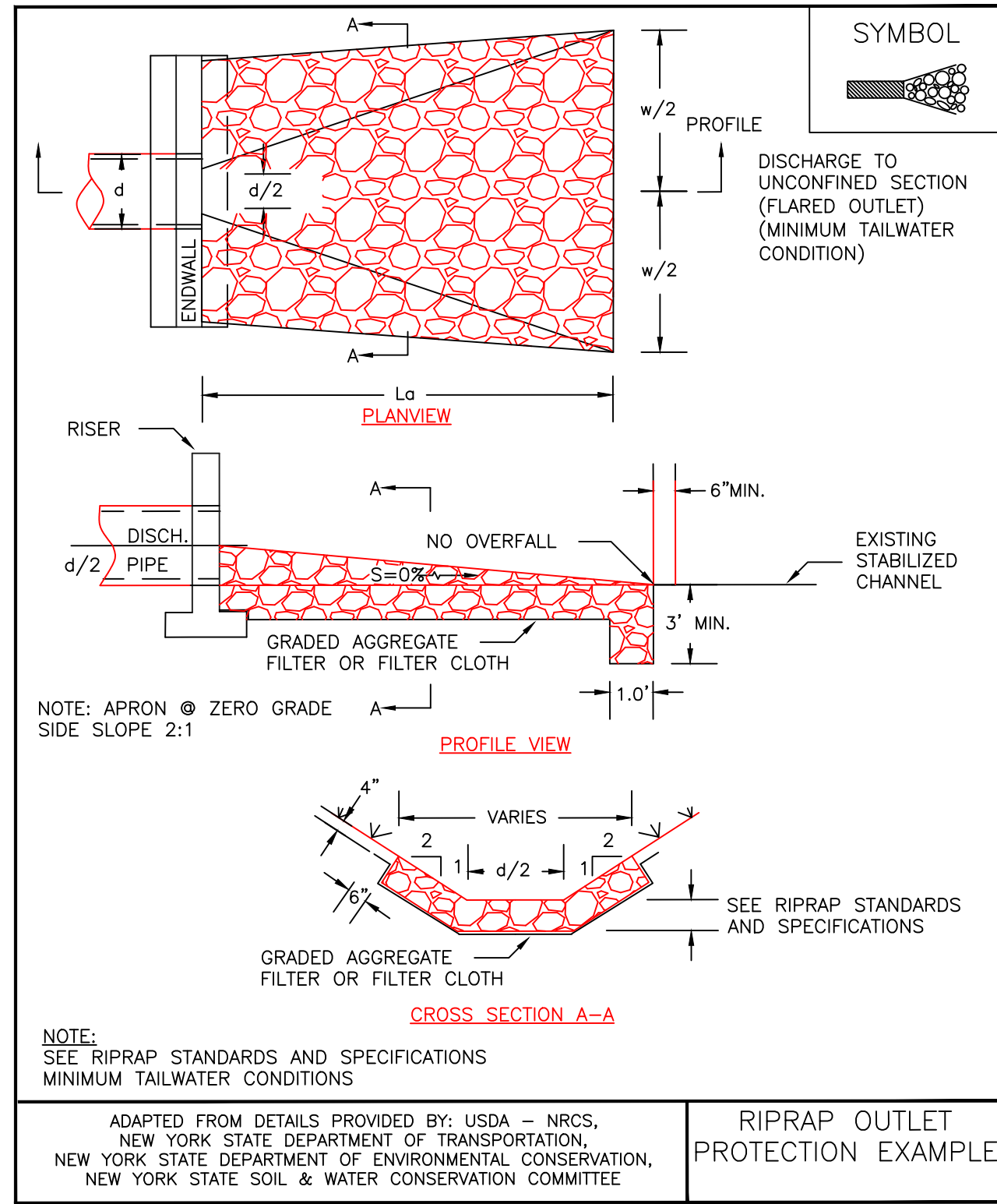

NOTES:

ALL APRONS SHALL BE CONSTRUCTED TO THE DIMENSIONS SHOWN. TERMINAL WIDTHS SHALL BE ADJUSTED AS NECESSARY TO MATCH RECEIVING CHANNELS.

ALL APRONS SHALL BE INSPECTED AT LEAST WEEKLY AND AFTER EACH RUNOFF EVENT. DISPLACED RIPRAP WITHIN THE APRON SHALL BE REPLACED IMMEDIATELY.

EXTEND RIPRAP ON BACK SIDE OF APRON TO AT LEAST 1/2 DEPTH OF PIPE ON BOTH SIDES TO PREVENT SCOUR AROUND THE PIPE.

RIPRAP APRON SCHEDULE				
ID	LENGTH (FT.)	WIDTH AT DISCHARGE (FT.)	WIDTH AT OUTLET (FT.)	REQ'D RIPRAP DIAMETER (FT.)
SD-01	15	5	19	0.5
SD-02	11	5	16	0.5
SD-03	11	5	15	0.5
SD-04	14	5	18	0.9
SD-1A	11	5	15	0.5
SD-2A 1	11	5	9	0.5
SD-2A 2	11	5	15	0.5
SD-2B 1	11	5	9	0.5
SD-2B 2	11	5	15	0.5
SD-3A 1	11	5	9	0.5
SD-3A 2	11	5	15	0.5

RIP RAP OUTLET PROTECTION
NOT TO SCALE

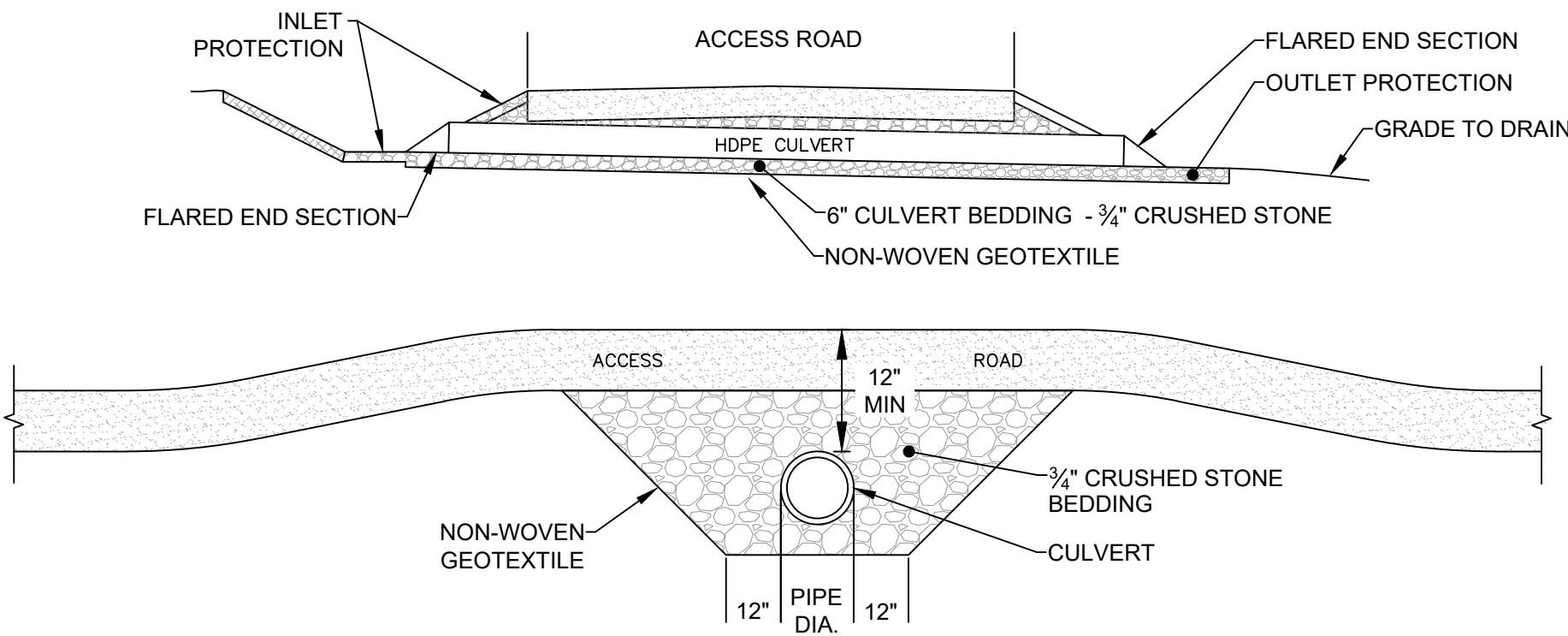

CULVERT SCHEDULE					
ID	DESCRIPTION	INV. IN	INV. OUT	LENGTH (FT)	SLOPE
SD-01	18" HDPE	265.00	264.50	21	0.02
SD-02	18" HDPE	261.00	260.40	37	0.02
SD-03	18" HDPE	312.00	308.64	25	0.13
SD-04	18" HDPE	288.82	286.50	88	0.03
SD-1A	18" HDPE	236.00	225.00	53	0.21
SD-2A 1	18" HDPE	277.50	277.00	35	0.01
SD-2A 2	18" HDPE	272.06	271.00	12	0.09
SD-2B 1	18" HDPE	246.50	246.00	30	0.02
SD-2B 2	18" HDPE	241.09	240.00	29	0.04
SD-3A 1	18" HDPE	281.50	281.00	30	0.02
SD-3A 2	18" HDPE	276.10	275.00	111	0.02

TYPICAL PERMANENT CULVERT
NOT TO SCALE

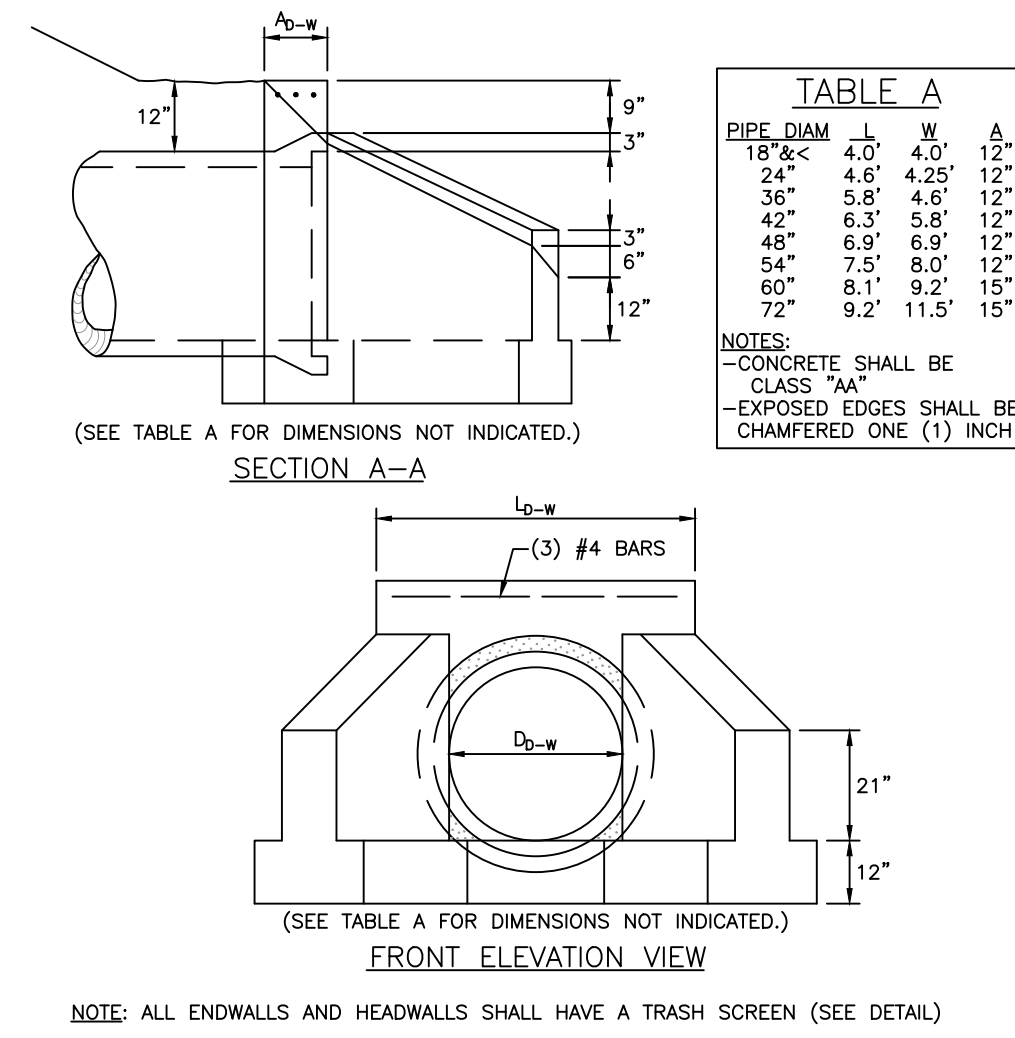

ENDWALL AND HEADWALL DETAIL
NOT TO SCALE

PIPE DIAM	L	W	A
18" \leq 24"	4.0'	4.0'	12"
24"	4.8'	4.25'	12"
36"	5.8'	4.8'	12"
42"	6.3'	5.8'	12"
48"	6.9'	6.9'	12"
54"	7.5'	8.0'	12"
60"	8.1'	9.2'	15"
72"	9.2'	11.5'	15"

NOTES:
- CONCRETE SHALL BE CLASS "AA"
- EXPOSED EDGES SHALL BE CHAMFERED ONE (1) INCH

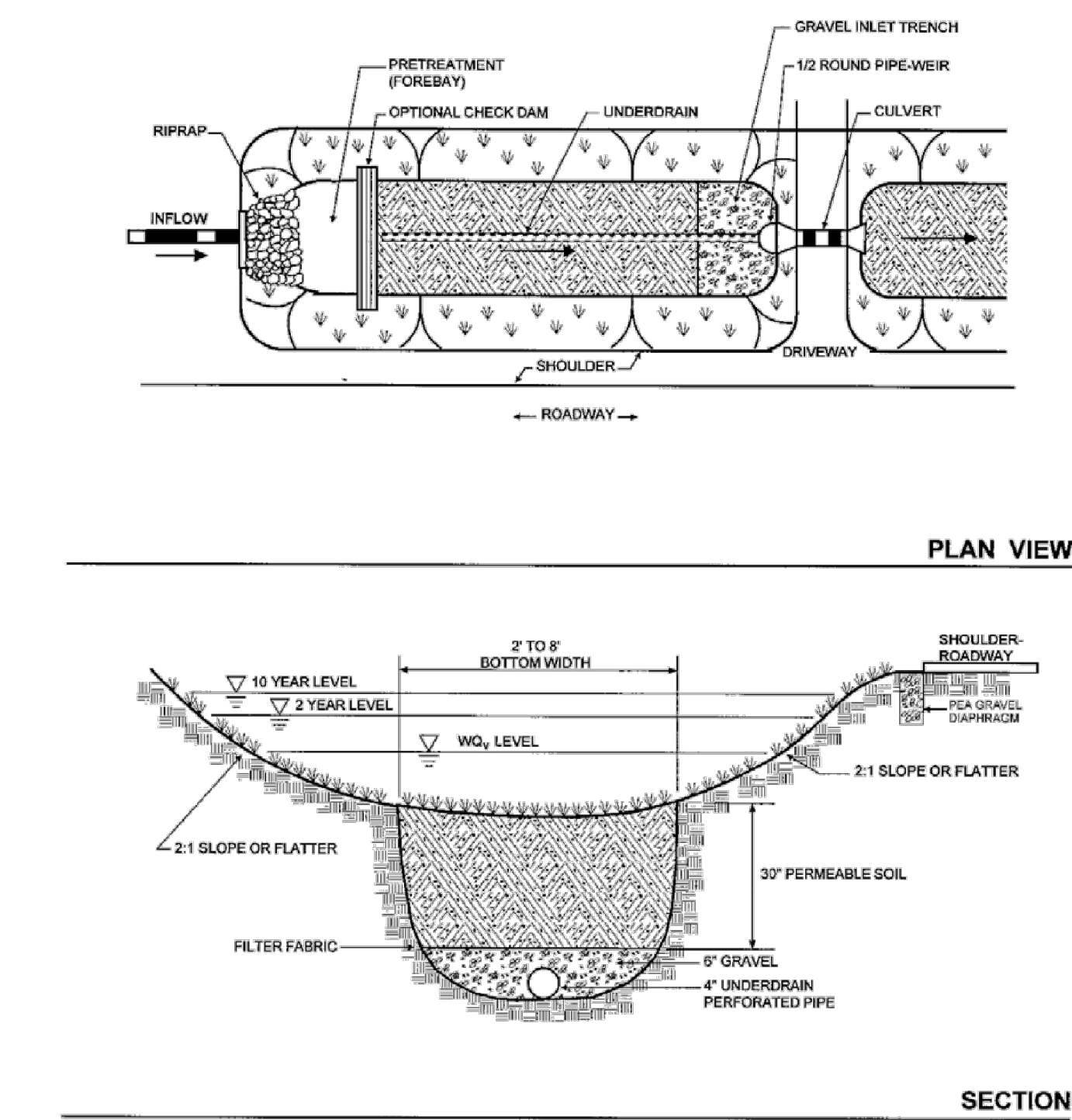

- NOTES:
- PERMEABLE SOIL TO MEET REQUIREMENTS IN NEW YORK STATE STORMWATER MANAGEMENT DESIGN MANUAL APPENDIX H.
 - MAINTAIN GRASS HEIGHT OF 4" TO 6" WITHIN DRY SWALE.
 - GRAVEL BEDDING TO CONSIST OF AASHTO NO. 2 STONE.
 - FILTER FABRIC TO BE MIRAFI 140N OR EQUAL.

DRY SWALE SECTION
NOT TO SCALE

NOTE: UNDER NEW YORK STATE EDUCATION LAW ARTICLE 145 (ENGINEERING), SECTION 7209 (2), IT IS A VIOLATION FOR ANY PERSON, UNLESS ACTING UNDER THE DIRECTION OF A LICENSED PROFESSIONAL ENGINEER, TO ALTER THIS DOCUMENT.

NOTE: THESE PLANS ARE ACCOMPANIED BY SUPPLEMENTAL DOCUMENTS. THESE DOCUMENTS ARE INTERRELATED AND ARE INTENDED TO BE USED TOGETHER. THESE DOCUMENTS ARE INTENDED TO BE USED FOR LOCAL APPROVAL PURPOSES ONLY.
NOT FOR CONSTRUCTION



Revisions:	
No.	Date:
1	SEPTEMBER 21, 2022
2	NOVEMBER 17, 2022

Drawn by:
A. REXROAT

Checked by:
S. MEERSMA

Approved by:
C. DUNCAN

**SCS DELL 014136 YORKTOWN, LLC
DELL AVENUE SOLAR FARM
FIXED-TILT GROUND MOUNT SOLAR ENERGY SYSTEM
DELL AVENUE, YORKTOWN, NEW YORK 10514**

Contract No:
431302

Scale:
AS SHOWN

Date:
AUGUST 30, 2022

Sheet:
DETAIL SHEET 3

Drawing No:
D-103

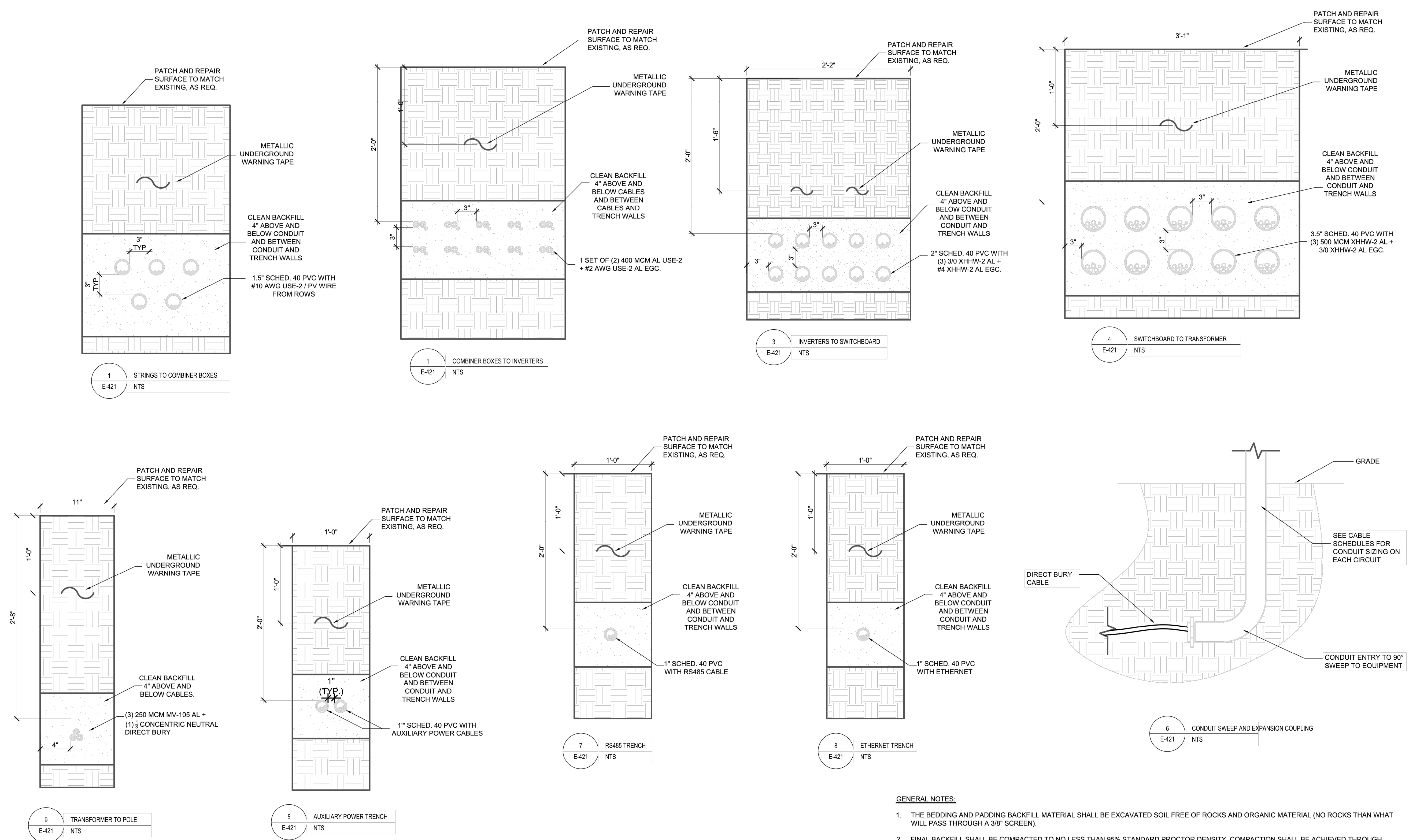

GENERAL NOTES:

1. THE BEDDING AND PADDING BACKFILL MATERIAL SHALL BE EXCAVATED SOIL FREE OF ROCKS AND ORGANIC MATERIAL (NO ROCKS THAN WHAT WILL PASS THROUGH A 3/8" SCREEN).
2. FINAL BACKFILL SHALL BE COMPACTED TO NO LESS THAN 95% STANDARD PROCTOR DENSITY. COMPACTION SHALL BE ACHIEVED THROUGH MECHANICAL MEANS IN LIFTS AS NECESSARY TO MEET REQUIRED DENSITY. MAXIMUM DENSITY AND IN PLACE DENSITY SHALL BE DETERMINED BY ASTM D-698 AND D-1556 RESPECTIVELY. NATIVE FILL FOR TRENCH SHALL BE SCREENED WITH NO GREATER THAN 2" WITH SUFFICIENT GRADATION TO ACHIEVE THE TARGET COMPACTION WITHOUT VOIDS.
3. SELECT SCREENED BACKFILL WILL BE REQUIRED IN ROCKY AREAS WHERE NATIVE MATERIAL IS NOT AVAILABLE.
4. CUT CABLE ENDS SHALL BE CAPPED DURING STORAGE AND CONSTRUCTION BEFORE TERMINATED IN ACCORDANCE WITH MANUFACTURER RECOMMENDATION TO PREVENT WATER INTRUSION.
5. ACTUAL CONDUIT ROUTING SHALL BE SHOWN ON THE "AS BUILT" DOCUMENTATION.
6. ALL CABLE AND CONDUIT ROUTING SHALL COMPLY WITH MINIMUM BEND RADII REQUIREMENTS IN NEC CH 9 TABLE 2.
7. ALL CONDUIT TO BE SEALED WITH STANDARD NEOPRENE OR RUBBER PLUG.
8. ANY TRENCHING OR EXCAVATION WITHIN 36" OF ANY RACK SUPPORT POST REQUIRES THE ORIGINAL SOIL AND COMPACTION TO 95% STANDARD PROCTOR DENSITY.
9. ROUTE ALL COMMUNICATIONS CABLE RUNS AT LEAST 8 INCHES FROM ANY POWER CABLE RUNS.

NOTE: UNDER NEW YORK STATE EDUCATION LAW ARTICLE 145 (ENGINEERING), SECTION 7209 (2), IT IS A VIOLATION FOR ANY PERSON, UNLESS ACTING UNDER THE DIRECTION OF A LICENSED PROFESSIONAL ENGINEER, TO ALTER THIS DOCUMENT.

NOTE: THESE PLANS ARE ACCOMPANIED BY A SUPPLEMENTAL DOCUMENTS. THESE DOCUMENTS ARE INTERRELATED AND ARE INTENDED TO BE USED TOGETHER. THESE DOCUMENTS ARE INTENDED TO BE USED FOR LOCAL APPROVAL PURPOSES ONLY.
NOT FOR CONSTRUCTION

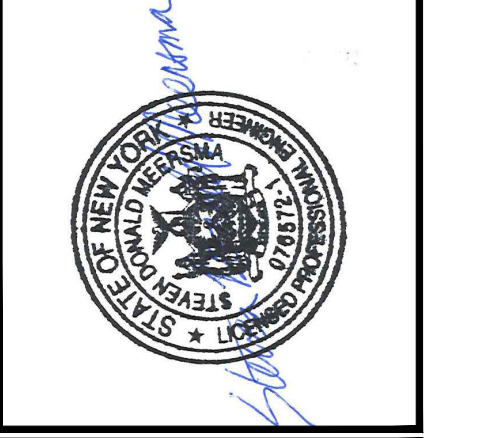

Revisions:

No.	Date:

Drawn by:
A. REXROAT
Checked by:
S. MEERSMA
Approved by:
C. DUNCAN

**SCS DELL 014136 YORKTOWN, LLC
DELL AVENUE SOLAR FARM
FIXED-TILT GROUND MOUNT SOLAR ENERGY SYSTEM
DELL AVENUE, YORKTOWN, NEW YORK 10514**

Contract No:
431302
Scale:
AS SHOWN
Date:
JUNE 14, 2022
Sheet:
DETAIL SHEET 6
Drawing No:
D-106

EROSION CONTROL MEASURES

EROSION AND SEDIMENT CONTROL MEASURES SHALL CONSIST OF NON-WOVEN FILTER FABRIC MATERIAL WITH A WIRE MESH BACKING, OR A WOVEN FABRIC (SILT FENCE). ALL MATERIAL SHALL BE NEW AND FREE FROM DEFECTS THAT WOULD COMPROMISE THE EFFECTIVENESS OF THE CONTROL MEASURES. AFTER COMPLETION, ALL MATERIAL SHALL BE DISPOSED PROPERLY. LOCATION OF EROSION AND SEDIMENT CONTROL STRUCTURES CAN BE SEEN ON THE SITE PLAN. NOTE: ALL WATER ARE LOCATED DOWN-GRADIENT FROM DISTRIBUTION STREET IF TOPSOIL IS TO BE STORED IN AN AREA NOT SHOWN ON THE SITE PLAN, DUE TO UNFORESEEN EVENTS, PRIOR TO STORING, THE DOWN-GRADIENT PERIMETER OF THE STORAGE AREA SHALL BE PROPERLY PROTECTED PER THE SPECIFICATIONS DETAILED ON THIS PLAN.

CONSTRUCTION HOUSEKEEPING

CONTRACTOR SHALL MAINTAIN THE PROJECT SITES IN ACCORDANCE WITH THE FOLLOWING PERFORMANCE STANDARDS:

MATERIAL STOCKPILING: MATERIAL RESULTING FROM CLEARING AND GRUBBING, GRADING, AND OTHER CONSTRUCTION ACTIVITIES, OR NEW MATERIAL DELIVERED TO THE SITE, SHALL BE STOCKPILED UPSLOPE OF DISTURBED AREAS. THE STOCKPILE AREAS SHALL HAVE THE PROPER EROSION AND SEDIMENT CONTROLS INSTALLED TO PREVENT MIGRATION OF SEDIMENTS AND MATERIALS.

STAGING, STORAGE, AND MARSHALLING AREAS: CONSTRUCTION MATERIALS AND EQUIPMENT SHALL BE STORED IN DESIGNATED STAGING AREAS AS INDICATED ON THE CONSTRUCTION DRAWINGS OR AS DIRECTED BY THE OWNER OR OWNER'S REPRESENTATIVE, OR ENGINEER. STAGING, STORAGE, AND MARSHALLING AREAS SHALL BE LOCATED IN AN AREA THAT MINIMIZES IMPACTS TO STORMWATER QUALITY, CHEMICALS, SOLVENTS, FERTILIZERS, AND OTHER TOXIC MATERIALS SHALL BE COLLECTED AND DISPOSED OF AT AN APPROVED SOLID WASTE OR CHEMICAL DISPOSAL FACILITY. BULK STORAGE OF FUEL MATERIALS WILL BE STAGED AT THE PROJECT MARSHALLING YARD PER SAFETY DATA SHEET (SDS) SPECIFICATION AND ENVIRONMENTAL HEALTH AND SAFETY STANDARDS, WHICHEVER IS MORE RESTRICTIVE.

EQUIPMENT CLEANING AND MAINTENANCE: ALL ON-SITE CONSTRUCTION VEHICLES SHALL BE MONITORED FOR LEAKS AND SHALL RECEIVE REGULAR PREVENTATIVE MAINTENANCE TO REDUCE THE RISK OF LEAKAGE. ANY EQUIPMENT LEAKING OIL, FUEL, OR HYDRAULIC OIL SHALL BE REPAIRED OR REMOVED FROM THE PROJECT SITE IMMEDIATELY. STORAGE, PARKING, MAINTENANCE, AND SERVICE OF CONSTRUCTION VEHICLES SHALL BE A MINIMUM OF 200 FEET FROM A WETLAND, WATERBODY, OR OTHER ECOLOGICALLY SENSITIVE AREA AND STORMWATER CONVEYANCE FEATURES OR WATER QUALITY TREATMENT BMPs. PETROLEUM PRODUCTS AND HYDRAULIC FLUIDS THAT ARE NOT IN VEHICLES SHALL BE STORED IN TIGHTLY SEALED CONTAINERS THAT ARE CLEARLY LABELED, ALL GASOLINE, DIESEL FUEL, OR OTHER FUEL STORAGE VESSELS WITH GREATER THAN 25-GALLON SHELL CAPACITY MUST HAVE SECONDARY CONTAINMENT CONSTRUCTED OF AN IMPERVIOUS MATERIAL CAPABLE OF CONTAINING A MINIMUM OF 110% OF THE SHELL CAPACITY.

DEBRIS AND OTHER MATERIALS: CONTRACTOR SHALL MANAGE ALL LITTER, CONSTRUCTION DEBRIS, AND CONSTRUCTION CHEMICALS EXPOSED TO STORMWATER TO PREVENT MATERIALS FROM BECOMING A SOURCE OF POLLUTION. ALL DEMOLITION WASTE, DEBRIS, AND RUBBISH GENERATED DURING CONSTRUCTION OF THE PROJECT SHALL BE PROPERLY REMOVED FROM THE SITE AS IT OCCURS. ALL MATERIALS SHALL BE PROPERLY DISPOSED OF OFF-SITE IN STRICT ACCORDANCE WITH ALL APPLICABLE LOCAL, STATE, AND FEDERAL REGULATIONS. THE CONTRACTOR SHALL PAY PARTICULAR ATTENTION TO THE PROPER HANDLING, STORAGE, AND DISPOSAL OF HAZARDOUS SUBSTANCES.

TRENCH OR FOUNDATION DEWATERING: TRENCH DEWATERING IS THE REMOVAL OF WATER FROM TRENCHES, FOUNDATIONS, COFFER DAMS, PONDING BASINS, AND OTHER AREAS WITHIN THE CONSTRUCTION AREA THAT RETAIN WATER AFTER EXCAVATION. IN MOST CASES THE COLLECTED WATER IS HEAVILY SITED AND HINDERS CORRECT AND SAFE CONSTRUCTION PRACTICES. THE CONTRACTOR SHALL REMOVE COLLECTED WATER FROM THE PONDED AREAS, EITHER THROUGH GRAVITY OR PUMPING, IN A MANNER THAT SPREADS IT THROUGH NATURAL WOODED OR VEGETATED BUFFERS OR TO AREAS THAT ARE SPECIFICALLY DESIGNED TO COLLECT THE MAXIMUM AMOUNT OF SEDIMENT LADEN WATER FROM DEWATERING TO FLOW OVER DISTURBED AREAS OF THE PROJECT SITES. OTHER MEASURES OR METHODS MAY BE UTILIZED AS REVIEWED AND APPROVED BY THE ENGINEER.

NON-STORMWATER DISCHARGES: CONTRACTOR SHALL IDENTIFY AND PREVENT CONTAMINATION BY NON-STORMWATER DISCHARGES.

CONCRETE WASHOUT AREAS: DESIGNATED CONCRETE WASHOUT AREAS SHALL BE PROVIDED AS NEEDED TO ALLOW CONCRETE TRUCKS TO WASHOUT OR DISCHARGE SURPLUS CONCRETE AND WASH WATER ON-SITE. CONCRETE WASHOUT AREAS SHALL BE A DIKED IMPERVIOUS AREA LOCATED A MINIMUM OF 100 FEET FROM A DRAINAGE WAY, WATERBODY, WETLAND AREA, OR INFILTRATION BMP. CONCRETE WASHOUT AREAS SHALL HAVE PROPER SIGNAGE AND BE CONSTRUCTED TO PREVENT CONTACT BETWEEN WASHWATER AND STORMWATER. THE CONTRACTOR IS RESPONSIBLE FOR IMPLEMENTATION AND MAINTENANCE OF CONCRETE WASHOUT AREAS. CONCRETE WASHOUT AREAS SHALL NOT BE FILLED BEFORE 95% OF DESIGN CAPACITY AND SHALL BE CLEANED OUT ONCE 75% CAPACITY HAS BEEN MET UNLESS A NEW FACILITY HAS BEEN CONSTRUCTED.

ADDITIONAL REQUIREMENTS: COMPLETION OF THE WORK WILL REQUIRE FREQUENT ACCESS TO VARIOUS PORTIONS OF THE PROJECT AREA FROM STATE AND LOCAL ROADWAYS. CONTRACTOR SHALL MONITOR PUBLIC ROADWAYS AND SHALL CLEAN PAVEMENT BY MEANS NECESSARY IN THE EVENT THAT SEDIMENT OR TRACKING IS OBSERVED. SIGNAGE SHALL BE POSTED AT INTERSECTIONS OF PROJECT ACCESS ROADS AND PUBLIC WAYS, STATING COMPANY NAME AND 24-HOUR CONTACT PHONE NUMBER.

TEMPORARY STABILIZATION FOR FROZEN CONDITIONS

SITE STABILIZATION: MULCHING SHOULD BE TRACKED INTO SOIL PRIOR TO FROZEN CONDITIONS, OR ANCHORED WITH NATURAL FIBER NETTING. APPLICATION OF MULCHING SHOULD BE PERFORMED PRIOR TO SIGNIFICANT SNOW FALL. STRAW MULCH ALONE IS USED FOR TEMPORARY STABILIZATION. IT SHALL BE APPLIED AT DOUBLE THE STANDARD RATE OF 2 TONS PER ACRE, MAKING THE APPLICATION RATE 4 TONS PER ACRE. OTHER MANUFACTURED MULCHES SHOULD BE APPLIED AT DOUBLE THE MANUFACTURER'S RECOMMENDED RATE. IN AREAS WHERE SOIL DISTURBANCE ACTIVITY HAS TEMPORARILY OR PERMANENTLY CEASED, THE APPLICATION OF SOIL STABILIZATION MEASURES SHOULD BE INITIATED BY THE END OF NEXT BUSINESS DAY AND COMPLETED WITHIN THREE DAYS. ACCUMULATED SNOW AND FROZEN CONDITIONS ALONE ARE NOT CONSIDERED STABILIZATION.

SLOPES: ALL SLOPES AND GRADES MUST BE PROPERLY STABILIZED WITH APPROVED METHODS. ROLLED EROSION CONTROL PRODUCTS MUST BE USED ON ALL SLOPES GREATER THAN 3H:1V, OR WHERE CONDITIONS FOR EROSION DICTATE SUCH MEASURES.

SETBACKS: A MINIMUM 25-FOOT BUFFER SHALL BE MAINTAINED FROM ALL PERIMETER CONTROLS SUCH AS SILT FENCE, MARK SILT FENCE WITH TALL STAKES THAT ARE VISIBLE ABOVE THE SNOW PACK. EDGES OF DISTURBED AREAS THAT DRAIN TO A WATERBODY WITHIN 100-FOOT WILL HAVE 2 ROWS OF SILT FENCE, 5-FOOT APART, INSTALLED ALONG THE CONTOUR.

SOIL STOCKPILES: STOCKPILED SOILS MUST BE PROTECTED BY THE USE OF ESTABLISHED VEGETATION, ANCHORED DOWN MULCH, ROLLED EROSION CONTROL PRODUCTS, OR OTHER DURABLE COVERING. SEDIMENT CONTROLS MUST BE INSTALLED DOWNSLOPE OF THE FILE TO CONTROL SEDIMENTATION TO UNDISTURBED LOCATIONS.

CONSTRUCTION ENTRANCE: ALL ENTRANCE AND EXIT LOCATIONS TO THE SITE MUST BE PROPERLY STABILIZED AND MUST BE MAINTAINED TO ACCOMMODATE SNOW MANAGEMENT AS SET FORTH IN THE NEW YORK SDESC.

SNOW MANAGEMENT: SNOW MANAGEMENT SHALL NOT DESTROY OR DEGRADE EROSION AND SEDIMENT CONTROL PRACTICES. PLOWING PERFORMED SHOULD NOT MIGRATE PLACED CRUSHED STONE OR ACCUMULATED MATTING DEBRIS WITHIN WATERBODIES, CONVEYANCES OR PROTECTED AREAS. PREPARE A SNOW MANAGEMENT PLAN WITH ADEQUATE STORAGE FOR SNOW AND CONTROL OF MELT WATER, REQUIRING CLEARED SNOW TO BE STORED IN A MANNER NOT AFFECTING ONGOING CONSTRUCTION ACTIVITIES. ENLARGE AND STABILIZE ACCESS POINTS TO PROVIDE FOR SNOW MANAGEMENT AND STOCKPILING. DRAINAGE STRUCTURES MUST BE KEPT OPEN AND FREE OF SNOW AND ICE DAMS. ALL DEBRIS OR ICE DAMS FROM PLOWING OPERATIONS THAT RESTRICT FLOW OF RUNOFF AND MELT WATER SHALL BE REMOVED.

FROST HEAVES: HEAVING FROST, FROZEN GROUND, WINTER CONDITIONS AND EQUIPMENT CAN AFFECT EROSION AND SEDIMENTATION CONTROL PRACTICES. EROSION CONTROL DEVICES SHALL BE CHECKED FOR DAMAGES AND REPAIRED BY TRAINED CONTRACTOR AND QUALIFIED INSPECTORS. DEFICIENCIES SHALL BE REPAIRED AND OR INSTALLED MEASURES SHALL BE REPLACED AS DEEMED NECESSARY. THIS IS ESPECIALLY IMPORTANT DURING THAWING PERIODS AND PRIOR TO SPRING RAIN EVENTS.

WINTER SHUTDOWN: IN THE EVENT OF TEMPORARY SHUTDOWN TO SOIL DISTURBING ACTIVITIES UNDER WINTER CONDITIONS, TEMPORARY STABILIZATION MEASURES SHALL BE IMPLEMENTED TO ALL DISTURBED AREAS AND SWPPP INSPECTIONS CAN BE REDUCED TO A MONTHLY FREQUENCY. THE CONTRACTOR SHALL REFER TO SOIL STABILIZATION MEASURES IN ACCORDANCE WITH THE NEW YORK STATE STANDARDS AND SPECIFICATIONS FOR EROSION AND SEDIMENT CONTROL (NOVEMBER 2016) AND SPDES GENERAL PERMIT GP-0-20-001.

PERMANENT CONSTRUCTION AREA SEEDING

FINAL STABILIZATION SHOULD BE IMPLEMENTED AT THE COMPLETION OF EACH PHASE. ONCE CONSTRUCTION IS COMPLETE, EXPOSED SOILS REQUIRE FINAL AND PERMANENT STABILIZATION. SOILS SHOULD BE GRADED SMOOTH AND LEVEL TO ELIMINATE RUTTING AND CONCENTRATED FLOWS, PONDING AND UNEVEN SURFACES FOR FUTURE MAINTENANCE ACTIVITIES. UNIMPROVED AREAS SHOULD BE RESTORED TO ORIGINAL GRADE UNLESS PERMITTED AND PLANNED FOR REQUIRED FUTURE MAINTENANCE. CONSERVED STOCKPILED TOPSOIL SHOULD BE UTILIZED FOR TOPDRESSING GRADED SUB-SOILS AT EXCAVATION SECTIONS. ANY SEVERELY COMPACTED SECTIONS WILL REQUIRE TILLING OR DISKING TO PROVIDE AN ADEQUATE ROOTING ZONE, TO A MINIMUM DEPTH OF 12". THE SEEDBED MUST BE PREPARED TO ALLOW GOOD SOIL TO SEED CONTACT, WITH THE SOIL NOT TOO SOFT AND NOT TOO COMPACT. ADEQUATE SOIL MOISTURE MUST BE PRESENT TO ACCOMPLISH THIS. IF SURFACE IS POWDER DRY OR STICKY WET, POSTPONE OPERATIONS UNTIL MOISTURE CHANGES TO A FAVORABLE CONDITION. REMOVE ALL STONES AND OTHER DEBRIS FROM THE SURFACE THAT ARE GREATER THAN 4 INCHES, OR THAT WILL INTERFERE WITH FUTURE MOWING OR MAINTENANCE.

SOIL AMENDMENTS SHOULD BE INCORPORATED INTO THE UPPER 2 INCHES OF SOIL WHEN FEASIBLE. THE SOIL SHOULD BE TESTED TO DETERMINE THE AMOUNTS OF AMENDMENTS NEEDED. APPLY GROUND AGRICULTURAL LIMESTONE TO ATTAIN A PH OF 6.0 IN THE UPPER 2 INCHES OF SOIL. IF SOIL MUST BE FERTILIZED BEFORE THE STONES AND OTHER DEBRIS CAN BE OBTAINED TO DETERMINE FERTILIZER NEEDS, APPLY COMMERCIAL FERTILIZER AT 600 LBS. PER ACRE OF 5-5 -10 OR EQUIVALENT.

IF SOILS ARE SOFT, MECHANICAL MULCHING MAY NOT BE AVAILABLE DUE TO THE INEVITABLE RUTTING WITH MULCHING EQUIPMENT.

ANY UPLAND AREAS THAT ARE DISTURBED SHALL BE STABILIZED USING PERMANENT SEED MIX AS SPECIFIED IN THE NEW YORK STATE STANDARDS AND SPECIFICATIONS FOR EROSION AND SEDIMENT CONTROL (SDESC), UNLESS DIRECTED OTHERWISE IN ASSOCIATED PERMITTING DOCUMENTS.

PROJECT CONSTRUCTION SEQUENCING NOTES

THE CONTRACTOR SHALL SUBMIT A CONSTRUCTION SEQUENCING OR CONSTRUCTION PHASING PLAN FOR OWNER APPROVAL THAT COMPLIES WITH THE PERMITTING REQUIREMENTS, THE PROJECT SWPPP, AND OTHER REQUIREMENTS AS IDENTIFIED BY LOCAL AND STATE AUTHORITIES. THE PLAN SHALL SHOW THAT ACTIVE LAND DISTURBANCE WILL BE LIMITED TO LESS THAN FIVE (5) CONTIGUOUS ACRES AND SHALL ADEQUATELY DISCUSS, BUT NOT BE LIMITED TO, THE FOLLOWING ITEMS:

1. THE CONTRACTOR SHALL COMPLY WITH THE REQUIREMENTS FOR TEMPORARY AND PERMANENT EROSION AND SEDIMENTATION CONTROL MEASURES AS OUTLINED IN THE PROJECT SWPPP OR AS DIRECTED BY THE OWNER.
2. PRIOR TO STARTING ANY WORK ON THE SITE, THE CONTRACTOR SHALL NOTIFY APPROPRIATE AGENCIES AND SHALL INSTALL EROSION CONTROL MEASURES AS SHOWN ON THE PLANS. THE CONTRACTOR SHALL OBTAIN ALL PERMITS, NOTIFY CITY OFFICIALS OF CONSTRUCTION COMMENCEMENT, AND SUBMIT CONSTRUCTION TIMETABLE.
3. PRIOR TO COMMENCING ON-SITE EARTHWORK ACTIVITIES, THE CONTRACTOR SHALL ESTABLISH THE CONSTRUCTION WORKSPACE LIMITS AND IDENTIFY AND MARK SENSITIVE RESOURCES.
4. THE CONTRACTOR SHALL INSTALL ALL TEMPORARY EROSION AND SEDIMENTATION CONTROL BEST MANAGEMENT PRACTICES (BMPs) IN ORDER TO PROTECT DOWN GRADIENT AREAS, WHERE APPROPRIATE, DIVERSION BMPs SHALL BE IMPLEMENTED TO DIRECT RUNOFF FROM UPGRADE AREAS AROUND THE PROJECT SITE.
5. ON-SITE CONSTRUCTION SEQUENCE SHALL START WITH THE MINIMUM AMOUNT OF CLEARING REQUIRED TO INSTALL EROSION CONTROL MEASURES. THIS INCLUDES, SILTATION FENCING, ANTI-TRACK PADS (STABILIZED CONSTRUCTION ENTRANCE), AND OTHER MEASURES NOTED ON THE PLAN. NO WORK SHALL TAKE PLACE UNTIL THE OWNER'S REPRESENTATIVE HAS INSPECTED AND APPROVED INSTALLED MEASURES.
6. AFTER PERMANENT EROSION AND SEDIMENTATION CONTROL MEASURES WITHIN THE CURRENT PHASE OF WORK ARE INSTALLED AND FUNCTIONING, THE CONTRACTOR SHALL OBTAIN OWNER APPROVAL BEFORE BEGINNING EARTHWORK IN THE SUBSEQUENT PHASE.
7. AFTER EROSION CONTROL MEASURES ARE INSTALLED THE TYPICAL SEQUENCE SHALL BE AS FOLLOWS:
 - a. REMOVE VEGETATION FROM PROPOSED DEVELOPMENT AREA. ALL STUMPS AND WOOD SHALL BE TAKEN OFF-SITE AND DISPOSED ACCORDINGLY.
 - b. REMOVE AND STOCKPILE TOPSOIL AFTER EROSION AND SEDIMENT CONTROL MEASURES HAVE BEEN INSTALLED. THE TOPSOIL SHALL BE SEEDED IMMEDIATELY AFTER STOCKPILING IN ORDER TO STABILIZE THE SLOPE AND LIMIT SEDIMENT RUNOFF. STOCKPILED TOPSOIL SHALL BE SEEDED AND MULCHED WHEN IT IS TO BE STORED MORE THAN 30 DAYS FROM TIME OF STOCKPILING. THE SITE CAN NOW BE REFORMED TO PROPOSED FINAL ELEVATIONS (LESS TOPSOIL DEPTH).
 - c. PROCEED WITH ALL WORK DEPICTED ON THE DEMOLITION PLAN, IF ANY.
 - d. PREPARE AND COMPACT SUBGRADE (IF AND AS DIRECTED) AND INSTALL DRAINAGE AND STORMWATER BMP'S IN ACCORDANCE WITH "GRADING AND STORMWATER MANAGEMENT PLAN".
 - e. EXCAVATE SOIL TO THE DEPTH NECESSARY TO CONSTRUCT GRAVEL ACCESS ROAD AND POROUS ASPHALT PAVEMENT. ALL REMOVED TOPSOIL SHALL BE UTILIZE ON SITE AS LOAM FOR GRASS AREAS. NO SOILS SHALL BE REMOVED FROM THE SUBJECT PROPERTY.
 - f. COMPLETE REMAINING GRADING REQUIRED AS SHOWN ON THE GRADING PLANS. INSTALL EROSION CONTROL MATTING ON ALL SLOPES OF 3H:1V OR GREATER (IF ANY), THEN SEED AND MULCH THE AREA.
 - g. INSTALL CONCRETE UTILITY PADS, FOOTINGS, PHOTOVOLTAIC PANELS, UTILITY POLES, FENCE AND GATES AND OTHER IMPROVEMENTS PER THE PLAN.
 - h. LOAM AND SEED FRONT YARD AND ALL REMAINING DISTURBED AREAS. UTILIZE EXISTING SITE SOIL WHERE POSSIBLE.
 - i. REMOVE ALL EROSION AND SEDIMENT STRUCTURES AFTER FINAL STABILIZATION AND ACCEPTANCE. IF STABILIZATION DOES NOT OCCUR (INCLUDING DUE TO SEASONAL CONDITIONS) IN ALL AREAS BEFORE CONTRACTOR HAS SATISFIED ALL OTHER CONDITIONS TO FINAL ACCEPTANCE, CONTRACTOR SHALL PROVIDE A PLAN (INCLUDING APPROPRIATE PERFORMANCE ASSURANCES) TO THE OWNER'S REPRESENTATIVE TO REMOVE SUCH EROSION CONTROL MEASURES AFTER STABILIZATION (AND ALLOWING CONTRACTOR TO ACHIEVE FINAL ACCEPTANCE), FOR ACCEPTANCE IN THE SOLE AND ABSOLUTE DISCRETION BY THE OWNER'S REPRESENTATIVE.
 - j. DURING THIS TIME ALL EROSION AND SEDIMENT STRUCTURES SHALL BE MAINTAINED IN PROPER WORKING ORDER. DISTURBED AREAS SHALL BE KEPT TO A MINIMUM AND SHALL ONLY TAKE PLACE WHERE IMMEDIATELY REQUIRED TO FURTHER CONSTRUCTION. IT IS DESIRABLE FOR AN EROSION PREVENTION TO MINIMIZE DISTURBED AREAS. FINAL GRADING AND SEEDING SHALL TAKE PLACE AS SOON AS PRACTICAL.

MULCH ANCHORING REQUIREMENTS

ON SLOPES GREATER THEN 3 PERCENT, STRAW MULCH WILL BE FIRMLY ANCHORED INTO SOIL UTILIZING ONE OF THE FOLLOWING METHODS:

- CRIMPING WITH A STRAIGHT OR NOTCHED MULCH CRIMPING TOOL;
- TRACK WALKING WITH DEEP-CREATED EQUIPMENT OPERATING UP AND DOWN THE SLOPE (MULCH CRIMPED PERPENDICULAR TO THE SLOPE) ON SLOPES <25 PERCENT;
- APPLICATION OF MULCH NETTING;
- APPLICATION OF 500 LB./ACRE OF WOOD FIBER MULCH OVER STRAW/HAY MULCH; AND
- COMMERCIALY AVAILABLE TACKIFIERS (EXCEPT WITHIN 100 FEET OF WATERBODIES OR WETLANDS).

CONSTRUCTION LITTER CONTROL

DURING CONSTRUCTION, ALL WRAPPING, BOXES, SCRAPS OF BUILDING MATERIAL, AND OTHER LITTER ITEMS SHALL BE DISPOSED OF PROPERLY BY USE OF DUMPSTER OR CARTED AWAY. THE SITE SHALL BE INSPECTED AND CLEANED DAILY DURING CONSTRUCTION.

PROTECTION OF POST-CONSTRUCTION STORMWATER BMPs

POST-CONSTRUCTION STORMWATER BMPs DESIGNED FOR WATER QUALITY TREATMENT SHALL NOT BE USED AS A SEDIMENT CONTROL DEVICES DURING CONSTRUCTION PHASE OF THE PROJECT. WHEN POSSIBLE, POST CONSTRUCTION STORMWATER BMP INSTALLATION SHALL OCCUR AFTER FINAL STABILIZATION IS ACHIEVED IN UPGRADE AREAS.

CONSTRUCTION PHASE STORMWATER SHALL BE DIVERTED AROUND POST-CONSTRUCTION STORMWATER QUALITY BMPs UNTIL FINAL STABILIZATION IS ACHIEVED IN UPGRADE AREAS. THE CONTRACTOR SHALL BE RESPONSIBLE FOR REPAIR OR REPLACEMENT OF BMP FILTER MATERIAL IN THE EVENT CONSTRUCTION PHASE STORMWATER IS DISCHARGED TO CONSTRUCTED BMPs. NATURE AND DEGREE OF REPAIR SHALL BE AS DIRECTED BY THE OWNER.

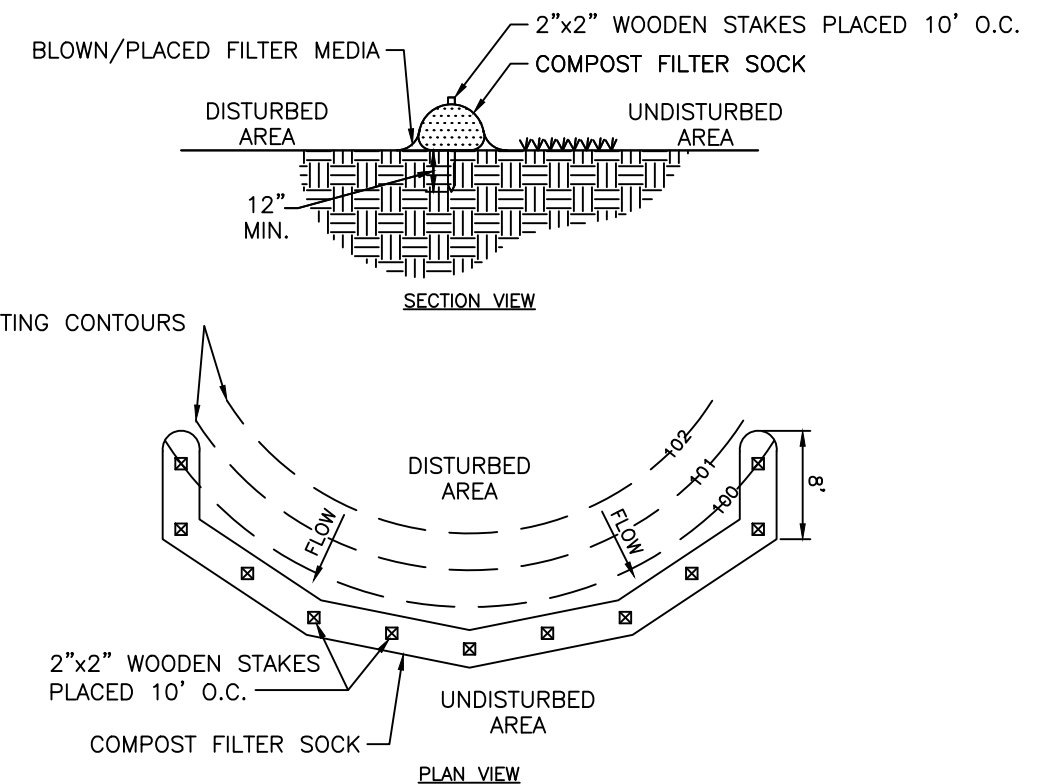

COMPOST FILTER SOCK
NOT TO SCALE

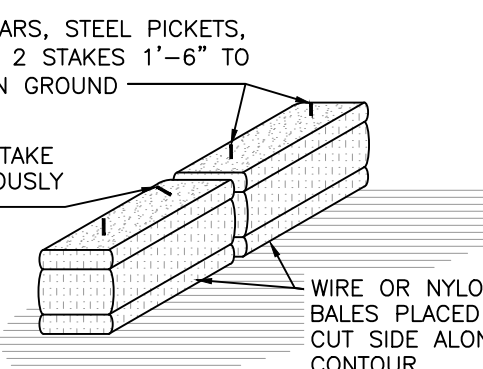
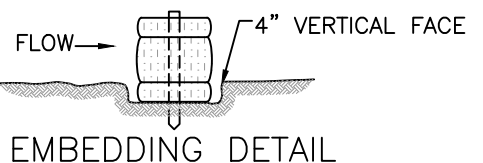

STRAW BALE BARRIER
NOT TO SCALE

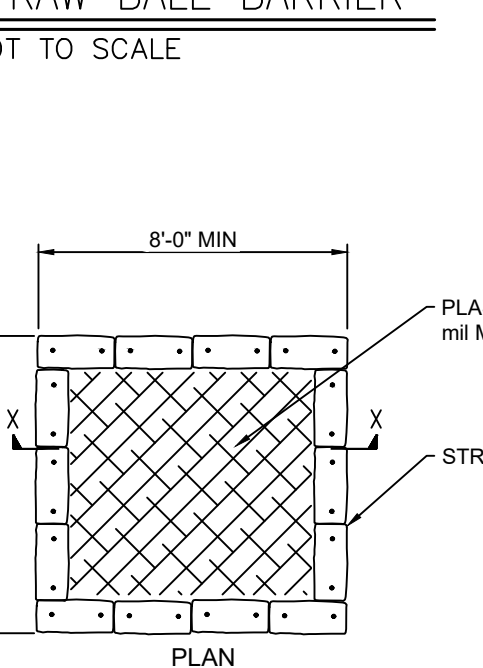

- NOTES:**
1. SUMP(S) SHALL BE LOCATED NEAR WORK SITES BUT SHALL BE PLACED AS FAR AWAY FROM WETLANDS, BUFFERS AND DRAINAGE SWALES AS PRACTICAL.
 2. SUMP(S) SHALL BE CLEANED AND WASTE CONCRETE REMOVED AND PROPERLY DISPOSED OF PERIODICALLY AND UPON COMPLETION OF WORK.
 3. A SIGN SHALL BE INSTALLED INDICATING "CONCRETE WASHOUT".

CONCRETE WASHOUT AREA
NOT TO SCALE

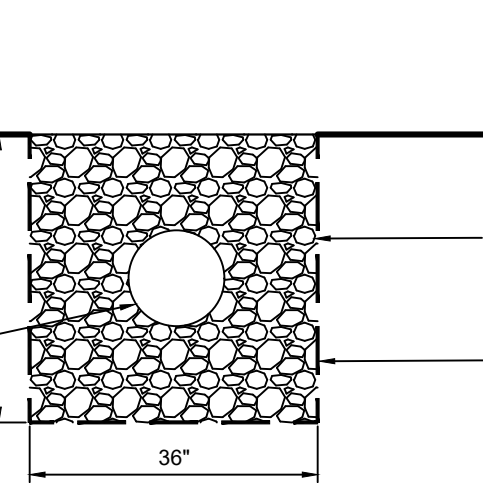

STORMWATER DIAPHRAGM
NOT TO SCALE

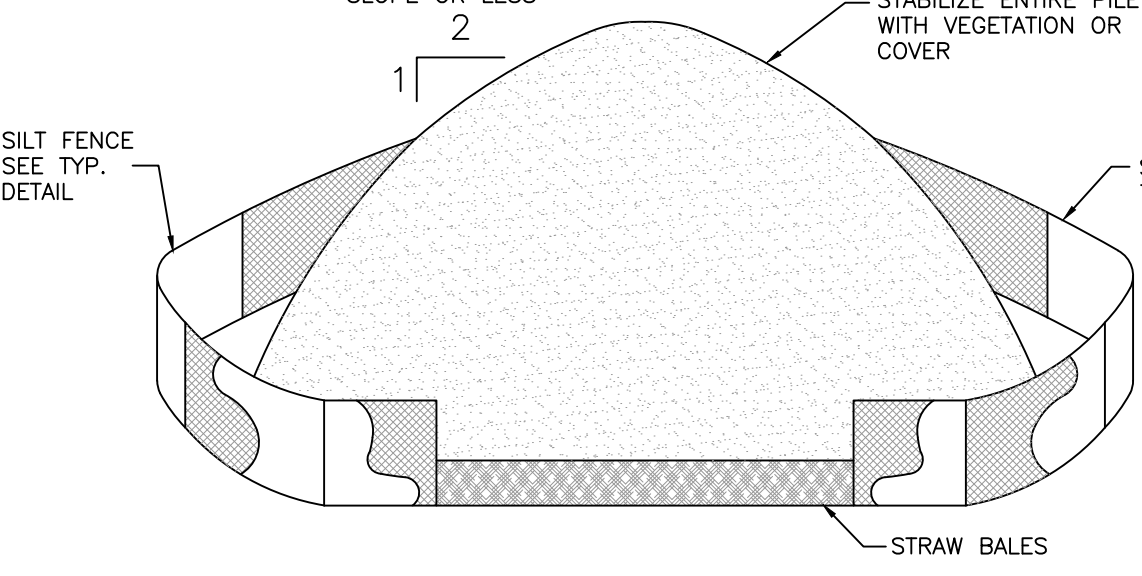

- INSTALLATION NOTES:**
1. AREA CHOSEN FOR STOCKPILING OPERATIONS SHALL BE DRY AND STABLE.
 2. MAXIMUM SLOPE OF STOCKPILE SHALL BE 2H:1V.
 3. UPON COMPLETION OF SOIL STOCKPILING, EACH PILE SHALL BE SURROUNDED WITH EITHER SILT FENCING OR STRAW BALES, THEN STABILIZED WITH VEGETATION OR COVERED.

TYPICAL SOIL STOCKPILE
NOT TO SCALE

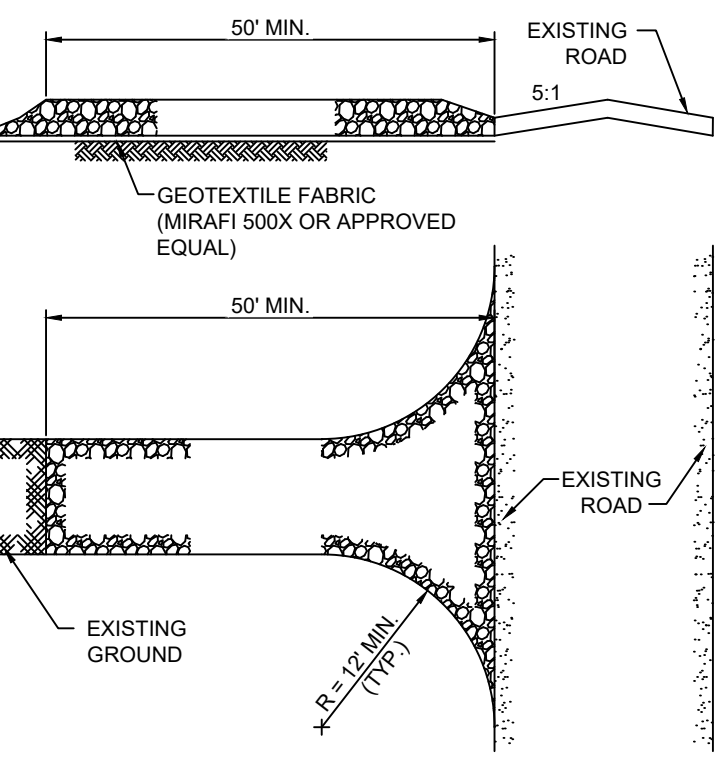

STABILIZED CONSTRUCTION ENTRANCE
NOT TO SCALE

1. WIDTH OF STABILIZED CONSTRUCTION ENTRANCE VARIES PER LOCATION. PROVIDE WIDTHS AS INDICATED ON PLAN SET.
2. STONE SIZE - USE 1'-4" STONE, OR RECLAIMED OR RECYCLED CONCRETE EQUIVALENT.
3. LENGTH - NOT LESS THAN 50 FEET.
4. THICKNESS - NOT LESS THAN SIX (6) INCHES.
5. WIDTH - TWELVE (12) FOOT MIN. BUT NOT LESS THAN THE FULL ROAD WIDTH AT POINTS WHERE INGRESS OR EGRESS OCCURS. PROVIDE TWENTY-FOUR (24) FOOT WIDTH IF THERE IS ONLY A SINGLE ENTRANCE TO SITE.
6. GEOTEXTILE - SHALL BE PLACED OVER THE ENTIRE AREA PRIOR TO LAYING THE STONE.
7. SURFACE WATER - ALL SURFACE WATER FLOWING OR DIVERTED TOWARD CONSTRUCTION ENTRANCE SHALL BE PIPED BENEATH THE ENTRANCE. IF PIPING IS IMPRACTICAL, A MOUNTABLE BERM WITH 5:1 SLOPES WILL BE PERMITTED.
8. MAINTENANCE - THE ENTRANCE SHALL BE MAINTAINED IN A CONDITION WHICH WILL PREVENT TRACKING OR FLOWING OF SEDIMENT ONTO PUBLIC RIGHTS-OF-WAY. ALL SEDIMENT SPILLED, DROPPED, WASHED OR TRACKED ONTO PUBLIC RIGHTS-OF-WAY MUST BE REMOVED IMMEDIATELY.
9. WHEN WASHING IS REQUIRED, IT SHALL BE DONE ON AN AREA STABILIZED WITH STONE THAT DRAINS INTO AN APPROVED SEDIMENT TRAPPING DEVICE.

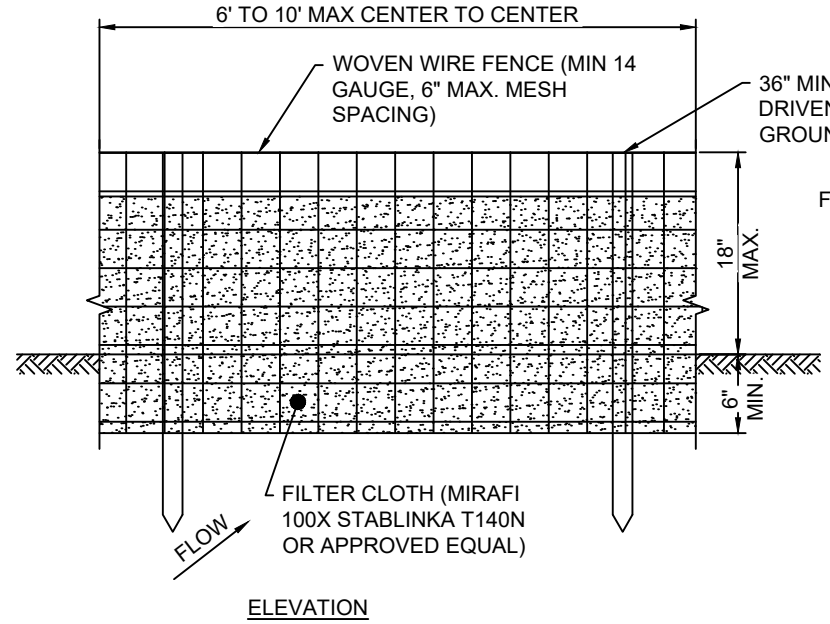

1. WOVEN WIRE FENCE SHALL BE FASTENED TO FENCE POSTS WITH WIRE TIES OR STAPLES.
2. FILTER CLOTH SHALL BE FASTENED SECURELY TO WOVEN WIRE FENCE WITH TIES SPACED EVERY 24" AT TOP AND MIDSECTION.
3. WHEN TWO SECTIONS OF FILTER CLOTH ADJOIN EACH OTHER THEY SHALL BE OVERLAPPED BY 6" AND FOLDED.
4. MAINTENANCE SHALL BE PERFORMED AS NEEDED AND MATERIAL REMOVED WHEN BUILD-UP REACHES 1/2 THE HEIGHT OF THE FENCE.

POSTS: STEEL "T" OR "U" TYPE OR 2" HARDWOOD.
FENCE: WOVEN WIRE. 14G GA 6" MAX MESH OPENING.
FILTER CLOTH: FILTER X, MIRAFI 100X, STABILINKA T140N OR APPROVED EQUAL.
PREFABRICATED UNIT: ENVIROFENCE OR APPROVED EQUAL.

SILT FENCE DETAILS
NOT TO SCALE

NOTE: THESE PLANS ARE ACCOMPANIED BY SUPPLEMENTAL DOCUMENTS. THESE DOCUMENTS ARE INTERRELATED AND ARE INTENDED TO BE USED TOGETHER. THESE DOCUMENTS ARE NOT TO BE USED FOR LOCAL APPROVAL PURPOSES ONLY.
NOT FOR CONSTRUCTION

NOTE: UNDER NEW YORK STATE EDUCATION LAW ARTICLE 145 (ENGINEERING), SECTION 7209 (2), IT IS A VIOLATION FOR ANY PERSON, UNLESS ACTING UNDER THE DIRECTION OF A LICENSED PROFESSIONAL ENGINEER, TO ALTER THIS DOCUMENT.

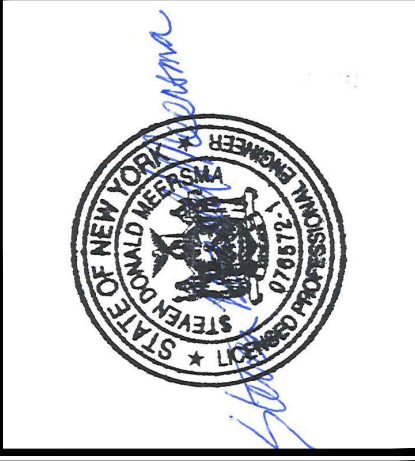

Revisions:	
No.	Date:

Drawn by:
A. REXROAT

Checked by:
S. MEERSMA

Approved by:
C. DUNCAN

SCS DELL 014136 YORKTOWN, LLC
DELL AVENUE SOLAR FARM
FIXED-TILT GROUND MOUNT SOLAR ENERGY SYSTEM
DELL AVENUE, YORKTOWN, NEW YORK 10514

Contract No:
431302

Scale:
AS SHOWN

Date:
AUGUST 30, 2022

Sheet:
DETAIL SHEET 8

Drawing No:
D-108

TRC Project No.: 431302.0000.0005